

The Semiflex® series



Standard F series

Symbiosis of performance and compact design
Bore diameter up to 120 mm
Torque (T_{KN}) 44 Nm to 7.040 Nm



Compact Plus C series

For extremely axially limited space
Bore diameter up to 100 mm
Torque (T_{KN}) 69 Nm to 7.040 Nm



Dynamic D series

The light-weight aluminum series
Bore diameter up to 35 mm
Torque (T_{KN}) 40 Nm to 180 Nm

Semiflex®

Semiflex® is a high-precision coupling in a compact design and with no restoring forces. Semiflex® offers large radial misalignment capacity in a very small envelope. Semiflex® is, by design, free of restoring forces. For highly dynamic applications, Semiflex® is also available in an aluminum series.

Standard F series

A symbiosis of performance, compact design and generous misalignment capacity.

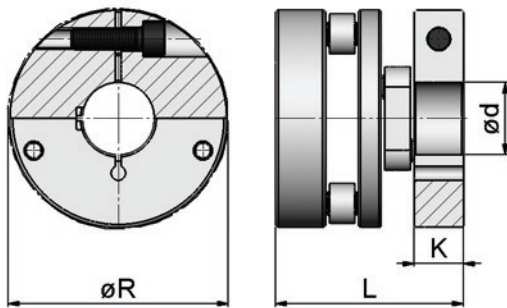

Hub version 1: clamp hub

	T_{KN} (Nm)	T_{Kmax} (Nm)	n_{max} (1/min)	ΔK_r (mm)	ΔK_s (mm)	ΔK_w (°)	C_T (kNm/rad)	J (kg cm ²)	m (kg)	$\varnothing R$ (mm)	L (mm)	K (mm)	$\varnothing d_{max}$ (mm)
F 45	44	71	5.000	1	1	1	8	2	0,5	52	60	16	22
F 70	69	112	4.200	1	1	1	13	8,4	1	72	68	20	35
F 230	230	460	2.900	1,6	1	1	53	34	2,7	94	104	27,5	44
F 265	265	530	2.700	1,6	1	1	61	50,1	3,2	104	104	27,5	50
F 320	316	635	2.500	3	1	1	73	100,4	4,1	124	104	27,5	70
F 440	437	920	2.300	2,4	1	1	105	74	5	100	143	38	45
F 575	575	1.220	2.100	2,4	1	1	140	147	6,5	120	143	38	60

Order Example 1: F 45.11 Ø16 Ø16 Order Example 2: F 320.11 Ø38 Ø40

F 320	11	Ø38 Ø40
Type Semiflex® Standard F 320	both sides clamp hub	bore diameters

To ensure the correct selection of the Semiflex® please use the TD Calculator of the column Semiflex® or please use our selection procedure and legend area to download the required information.

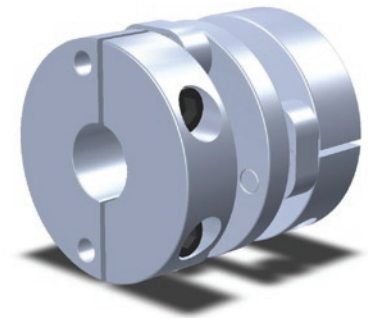
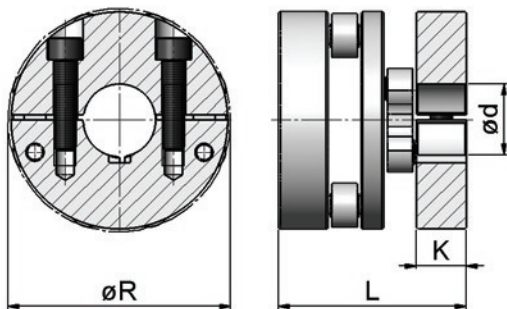

Hub version 2: split-clamp hub

	T_{KN} (Nm)	$T_{K_{max}}$ (Nm)	n_{max} (1/min)	ΔK_r (mm)	ΔK_a (mm)	ΔK_w (°)	C_T (kNm/rad)	J (kg cm ²)	m (kg)	$\varnothing R$ (mm)	L (mm)	K (mm)	$\varnothing d_{max}$ (mm)
F 70	69	112	4.200	1	1	1	13	8,4	1	72	68	20	25
F 230	230	460	2.900	1,6	1	1	53	34	2,7	94	104	27,5	30
F 265	265	530	2.700	1,6	1	1	61	50,1	3,2	104	104	27,5	35
F 320	316	635	2.500	3	1	1	73	100,4	4,1	124	104	27,5	45
F 575	575	1.220	2.100	2,4	1	1	140	147	6,5	120	143	38	35

Order Example 1: F 70.22 $\varnothing 20$ $\varnothing 25$ Order Example 2: F 320.22 $\varnothing 38$ $\varnothing 40$

F 320	22	$\varnothing 38$ $\varnothing 40$
Type Semiflex® Standard F 320	both sides split-clamp hub	bore diameters

To ensure the correct selection of the Semiflex® please use the TD Calculator of the column Semiflex® or please use our selection procedure and legend area to download the required information.

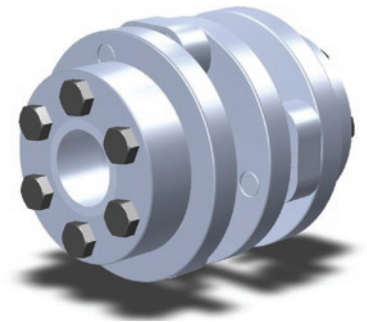
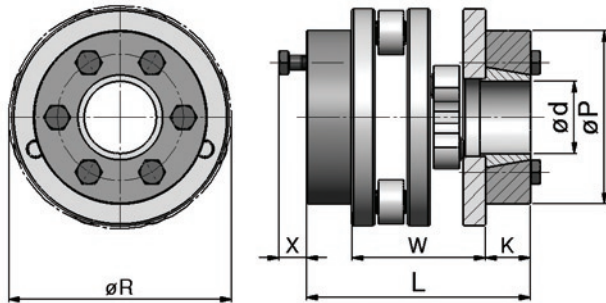

Hub version 3: locking-assembly

	T_{kN} (Nm)	T_{kmax} (Nm)	n_{max} (1/min)	ΔK_r (mm)	ΔK_s (mm)	ΔK_w (°)	C_T (kNm/rad)	J (kg cm ²)	m (kg)	ØR (mm)	L (mm)	X (mm)	W (mm)	K (mm)	ØP (mm)	standard bore diameters (mm)
F 230	230	460	2.900	1,6	1	1	53	32,4	3,1	94	116	15	74	21	76	25, 28, 30
F 265	265	530	2.700	1,6	1	1	61	37,1	3,2	104	116	15	74	19	66	25, 28, 30
F 320	316	635	2.500	3	1	1	73	77,1	4,5	124	116	15	74	21	76	25, 28, 30
F 440	437	920	2.300	2,4	1	1	105	79	5,6	100	116	15	101	19	66	25, 28, 30
F 575	575	1.220	2.100	2,4	1	1	140	126	6,8	120	151	17	101	25	96	30, 32, 35, 40
F 725	725	1.530	2.000	2,4	1	1	175	248	9,9	140	161	23	101	30	115	42, 45, 50
F 830	828	1.755	1.900	4	1	1	201	360	11,6	160	161	23	101	30	115	42, 45, 50
F 1120	1.120	2.730	1.700	3	1	0,8	313	295	12	143	188	17	134	30	115	30, 35, 40
F 1370	1.370	3.340	1.600	3	1	0,8	383	505	15,5	163	194	23	134	30	115	42, 45, 50
F 1580	1.580	3.845	1.500	4	1	0,8	441	795	19	183	202	24	134	34	120	50, 55, 60
F 2010	2.010	4.915	1.500	3,2	1	0,7	563	610	18	163	202	24	155	34	120	50, 55, 60
F 2390	2.390	5.855	1.400	3,2	1	0,7	671	1.110	25,5	183	235	30	155	40	155	60, 65, 70
F 2700	2.700	6.600	1.300	4,4	1	0,5	756	1.540	30	203	235	30	155	40	155	60, 65, 70
F 4220	4.220	11.300	1.200	4	2	0,3	1.295	1.725	33	200	276	30	196	40	155	60, 65, 70
F 5620	5.620	15.050	1.100	5,4	2	0,3	1.725	3.975	49	250	284	31	196	44	170	70, 75, 80
F 7040	7.040	18.840	1.000	6,6	2	0,3	2.159	7.700	66	300	296	30	196	50	185	80, 85, 90

Order Example 1: F 70.33 Ø20 Ø25 Order Example 2: F 320.33 Ø30 Ø30

F 320	33	Ø30 Ø30
Type Semiflex® Standard F 320	both sides locking-assembly	bore diameters

To ensure the correct selection of the Semiflex® please use the TD Calculator of the column Semiflex® or please use our selection procedure and legend area to download the required information.

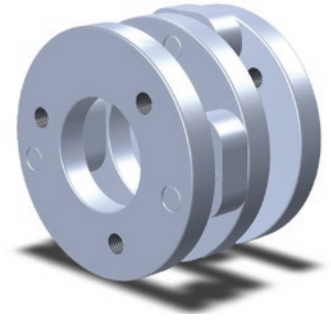
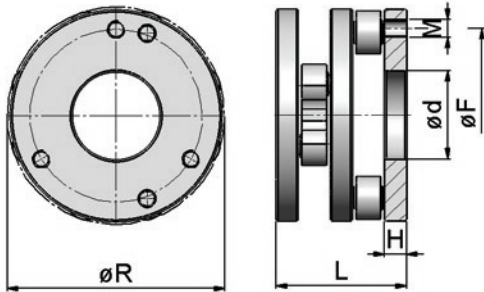

Hub version 5: flange-mounting

	T_{kn} (Nm)	TK_{max} (Nm)	n_{max} (1/min)	ΔK_r (mm)	ΔK_a (mm)	ΔK_w (°)	C_T (kNm/rad)	J (kg cm ²)	m (kg)	$\varnothing R$ (mm)	H (mm)	$\varnothing d$ (mm)	L (mm)	$\varnothing F$ (mm)	M
F 45	44	71	5.000	1	1	1	8	1	0,4	52	8	22	44	35	3xM6
F 70	69	112	4.200	1	1	1	13	5	0,6	72	8	25	44	56	3xM6
F 230	230	460	2.900	1,6	1	1	53	20	1,6	94	12,5	45	74	70	3xM10
F 265	265	530	2.700	1,6	1	1	61	31	2	104	12,5	45	74	70	3xM10
F 320	316	635	2.500	3	1	1	73	64	2,9	124	12,5	50	74	98	3xM10
F 440	437	920	2.300	2,4	1	1	105	45	3,3	100	17	40	101	70	3xM16
F 575	575	1.220	2.100	2,4	1	1	140	90	4,3	120	17	50	101	90	3xM16
F 725	725	1.530	2.000	2,4	1	1	175	165	5,8	140	17	50	101	110	3xM16
F 830	828	1.755	1.900	4	1	1	201	271	7,1	160	17	60	101	120	3xM16
F 1120	1.120	2.730	1.700	3	1	0,8	313	249	9,1	143	26	55	134	100	3xM20
F 1370	1.370	3.340	1.600	3	1	0,8	383	401	11	163	26	60	134	120	3xM20
F 1580	1.580	3.845	1.500	4	1	0,8	441	656	14	183	26	70	134	140	3xM20
F 2010	2.010	4.915	1.500	3,2	1	0,7	563	484	14	163	31	60	155	115	5xM20
F 2390	2.390	5.855	1.400	3,2	1	0,7	671	795	17	183	31	70	155	135	5xM20
F 2700	2.700	6.600	1.300	4,4	1	0,5	756	1.214	21	203	31	80	155	150	5xM20
F 4220	4.220	11.300	1.200	4	2	0,3	1.295	1.339	23	200	33	80	196	150	5xM24
F 5620	5.620	15.050	1.100	5,4	2	0,3	1.725	3.209	34	250	33	100	196	200	5xM24
F 7040	7.040	18.840	1.000	6,6	2	0,3	2.159	6.238	42	300	33	160	196	250	5xM24

Order Example 1: F 45.55 Order Example 2: F 2010.55

F 2010	55
Type Semiflex® Standard F 2010	both sides flange-mounting

To ensure the correct selection of the Semiflex® please use the TD Calculator of the column Semiflex® or please use our selection procedure and legend area to download the required information.

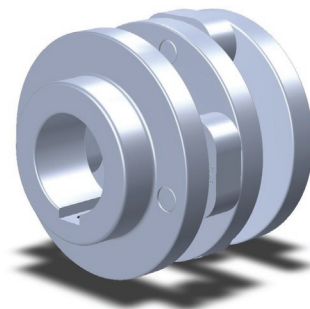
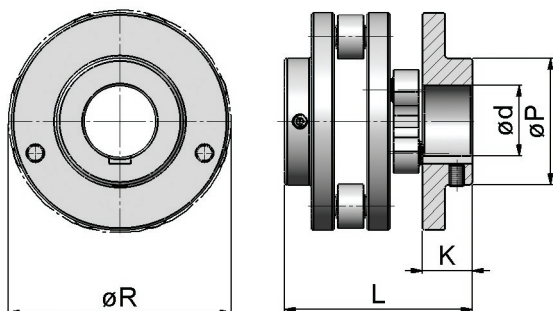

Hub version 6: standard hub

	T_{KN} (Nm)	$T_{K,max}$ (Nm)	n_{max} (1/min)	ΔK_v (mm)	ΔK_a (mm)	ΔK_w (°)	C_r (kNm/rad)	J (kg cm ²)	m (kg)	$\varnothing R$ (mm)	L (mm)	$\varnothing P$ (mm)	K (mm)	$\varnothing d_{max}$ (mm)
F 45	44	71	5.000	1	1	1	8	2	0,5	52	60	50	16	26
F 70	69	112	4.200	1	1	1	13	8,4	1	72	68	70	20	40
F 230	230	460	2.900	1,6	1	1	53	23,6	2,2	94	104	56	27,5	40
F 265	265	530	2.700	1,6	1	1	61	34,7	2,6	104	104	65	27,5	50
F 320	316	635	2.500	3	1	1	73	70,4	3,6	124	104	70	27,5	50
F 440	437	920	2.300	2,4	1	1	105	50	4	100	143	53	38	32
F 575	575	1.220	2.100	2,4	1	1	140	99	5,2	120	143	70	38	45
F 725	725	1.530	2.000	2,4	1	1	175	183	7	140	149	85	41	55
F 830	828	1.755	1.900	4	1	1	201	303	9,1	160	163	90	48	60
F 1120	1.120	2.730	1.700	3	1	0,8	313	270	10,5	143	162	77	40	45
F 1370	1.370	3.340	1.600	3	1	0,8	383	435	13	163	170	90	44	60
F1580	1.580	3.845	1.500	4	1	0,8	441	710	16	183	182	90	50	60
F 2010	2.010	4.915	1.500	3,2	1	0,7	563	520	15,5	163	185	85	46	55
F 2390	2.390	5.855	1.400	3,2	1	0,7	671	850	19	183	195	90	51	60
F 2700	2.700	6.600	1.300	4,4	1	0,5	756	1.280	23,5	203	205	95	56	65
F 4220	4.220	11.300	1.200	4	2	0,3	1.295	1.475	27	200	236	110	53	70
F 5620	5.620	15.050	1.100	5,4	2	0,3	1.725	3.525	41	250	266	120	68	80
F 7040	7.040	18.840	1.000	6,6	2	0,3	2.159	7.350	63	300	322	160	96	100

Order Example 1: F 70.66 Ø25 Ø25 Order Example 2: F 320.66 Ø38 Ø40

F 320	66	Ø38 Ø40
Type Semiflex® Standard F 320	both sides standard hub	bore diameters

To ensure the correct selection of the Semiflex® please use the TD Calculator of the column Semiflex® or please use our selection procedure and legend area to download the required information.

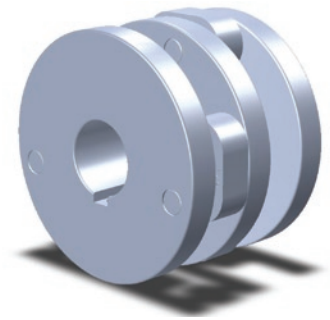
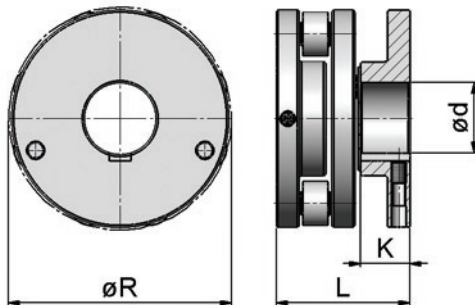

Hub version 7: internal hub

	T_{KN} (Nm)	$T_{K,max}$ (Nm)	n_{max} (1/min)	ΔK_i (mm)	ΔK_a (mm)	ΔK_w (°)	C_t (kNm/rad)	J (kg cm ²)	m (kg)	ØR (mm)	L (mm)	K (mm)	Ød _{max} (mm)
F 70	69	112	4.200	1	1	1	13	5,1	0,8	72	44	20	25
F 230	230	460	2.900	1,6	1	1	53	22,4	2,1	94	74	27,5	25
F 265	265	530	2.700	1,6	1	1	61	32,4	2,4	104	74	27,5	35
F 320	316	635	2.500	3	1	1	73	68,5	3,4	124	74	27,5	45
F 575	575	1.220	2.100	2,4	1	1	140	95	5	120	101	38	30
F 725	725	1.530	2.000	2,4	1	1	175	173	6,6	140	101	41	45
F 830	828	1.755	1.900	4	1	1	201	291	8,5	160	101	48	60
F 1370	1.370	3.340	1.600	3	1	0,8	383	430	13	163	134	44	40
F 1580	1.580	3.845	1.500	4	1	0,8	441	700	15,5	183	134	50	60
F 2390	2.390	5.855	1.400	3,2	1	0,7	671	840	18,5	183	155	51	60
F 2700	2.700	6.600	1.300	4,4	1	0,5	756	1.280	23	203	155	56	70
F 5620	5.620	15.050	1.100	5,4	2	0,3	1.725	3.500	40	250	196	68	90
F 7040	7.040	18.840	1.000	6,6	2	0,3	2.159	7.200	66	300	196	96	120

Order Example 1: F 70.77 Ø20 Ø20 Order Example 2: F 320.77 Ø30 Ø35

F 320	77	Ø30 Ø35
Type Semiflex® Standard F 320	both sides internal hub	bore diameters

To ensure the correct selection of the Semiflex® please use the TD Calculator of the column Semiflex® or please use our selection procedure and legend area to download the required information.

1. Calculation of the design torque. Please multiply your continuous torque by the required performance factor (table 1) and the required service factor (table 2) to get the design torque.

An alternative:

simply use under www.schmidt-kupplung.com the

TD Calculator of the column Semiflex®

5. Make sure that the misalignment capability is sufficient. There is a trade-off between the radial, axial and angular misalignment capabilities. Be certain that the combined percentages of each do not exceed 100%.

Table 1: performance factor

speed range 1/min	service life (h)	performance factor
0-500	5.000	1,8
0-500	10.000	2,3
0-500	20.000	2,8
500-1.000	5.000	2,3
500-1.000	10.000	2,8
500-1.000	20.000	3,5
1.000-2.000	5.000	2,8
1.000-2.000	10.000	3,6
1.000-2.000	20.000	4,4
2.000-3.000	5.000	3,2
2.000-3.000	10.000	4
2.000-3.000	20.000	4,8

Table 2: service factor

uniform	1
light shocks	1,5
medium shocks	2
heavy shocks	2,5

2. Select a coupling size that has a continuous torque rating greater than your calculated design torque.
3. Make sure that the peak torque of the application does not exceed the maximum torque rating of the coupling.
4. Please check the coupling maximum speed to be sure it is within the rated maximum speed.

Legend

Performance

T_{KN}	continuous torque rating of the coupling (Nm)
$T_{K\ max}$	maximum torque capacity of the coupling (Nm)
$n_{\ max}$	maximum speed of the coupling (1/min)
ΔK_r	maximum radial misalignment capacity (mm)
ΔK_a	maximum axial misalignment capacity (mm)
ΔK_w	maximum angular misalignment capacity (°)
C_T	torsional stiffness (kNm/rad)
J	moment of inertia (kg cm ²)
m	weight of the coupling (kg)

Dimension

$\varnothing R$	swing diameter (mm)
H	disc thickness (mm)
L	coupling length (mm)
$\varnothing P$	hub diameter (mm)
K	total hub length (mm)
X	mounting space (mm)
W	coupling basis (mm)
$\varnothing F$	bolt circle diameter (mm)
M	number of threaded bores x bolt size
$\varnothing d$	bore diameter (mm)

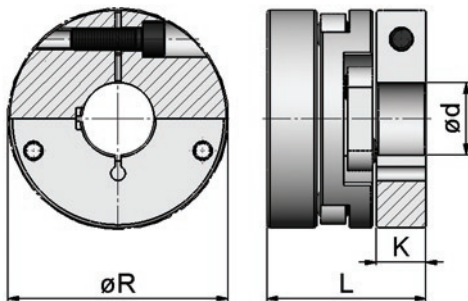

Hub version 1: clamp hub

	T_{KN} (Nm)	TK_{max} (Nm)	n_{max} (1/min)	ΔK_i (mm)	ΔK_a (mm)	ΔK_{st} (°)	C_T (kNm/rad)	J (kg cm ²)	m (kg)	$\varnothing R$ (mm)	L (mm)	K (mm)	$\varnothing d_{max}$ (mm)
C 70	69	112	3.400	1	1	1	13	8,9	1,1	72	59	20	35
C 230	230	460	2.300	1,6	1	1	53	36,8	3	94	88	27,5	44
C 265	265	530	2.200	1,6	1	1	61	54,2	3,4	104	88	27,5	50
C 320	316	635	2.000	3	1	1	73	104,8	4,2	124	88	27,5	70
C 575	575	1.220	1.700	2,4	1	1	140	155	6,9	120	120,5	38	60

Order Example 1: C 70.11 Ø25 Ø25 Order Example 2: C 320.11 Ø38 Ø40

C 320	11	Ø38 Ø40
Type Semiflex® Compact Plus C 320	both sides clamp hub	bore diameters

To ensure the correct selection of the Semiflex® please use the TD Calculator of the column Semiflex® or please use our selection procedure and legend area to download the required information.

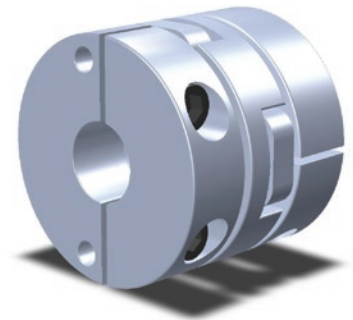
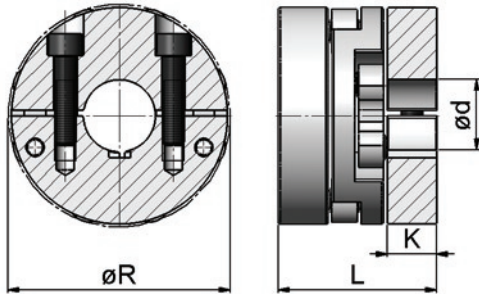

Hub version 2: split-clamp hub

	T_{KN} (Nm)	T_{Kmax} (Nm)	n_{max} (1/min)	ΔK_1 (mm)	ΔK_2 (mm)	ΔK_w (°)	C_1 (kNm/rad)	J (kg cm ²)	m (kg)	ØR (mm)	L (mm)	K (mm)	Ød _{max} (mm)
C 70	69	112	3.400	1	1	1	13	8,9	1,1	72	59	20	25
C 230	230	460	2.300	1,6	1	1	53	36,8	3	94	88	27,5	30
C 265	265	530	2.200	1,6	1	1	61	54,2	3,4	104	88	27,5	35
C 320	316	635	2.000	3	1	1	73	104,8	4,2	124	88	27,5	45
C 575	575	1.220	1.700	2,4	1	1	140	155	6,9	120	120,5	38	35

Order Example 1: C 70.22 Ø20 Ø20

Order Example 2: C 320.22 Ø38 Ø40

C 320	22	Ø38 Ø40
Type Semiflex® Compact Plus C 320	both sides split-clamp hub	bore diameters

To ensure the correct selection of the Semiflex® please use the TD Calculator of the column Semiflex® or please use our selection procedure and legend area to download the required information.

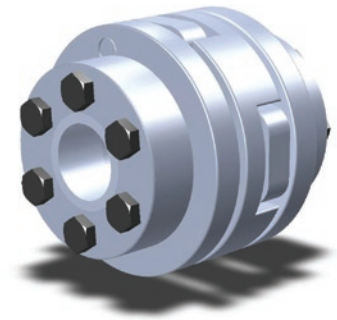
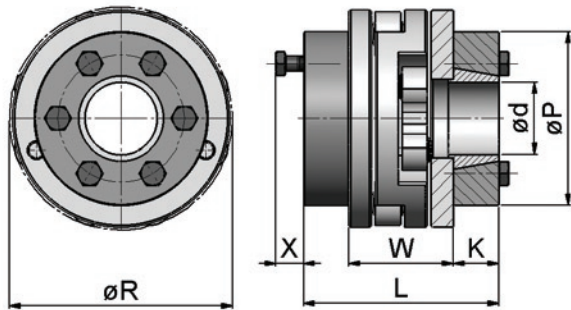

Hub version 3: locking-assembly

	T_{KN} (Nm)	$T_{K,max}$ (Nm)	n_{max} (1/min)	ΔK_r (mm)	ΔK_a (mm)	ΔK_w (°)	C_T (kNm/rad)	J (kg cm ²)	m (kg)	$\varnothing R$ (mm)	L (mm)	X (mm)	W (mm)	K (mm)	$\varnothing P$ (mm)	standard bore diameters (mm)
C 230	230	460	2.300	1,6	1	1	53	34,3	3,2	94	100	15	58	21	76	25, 28, 30
C 265	265	530	2.200	1,6	1	1	61	41,2	3,4	104	100	15	58	21	66	25, 28, 30
C 320	316	635	2.000	3	1	1	73	81,5	4,6	124	100	15	58	21	76	25, 28, 30
C 575	575	1.220	1.700	2,4	1	1	140	134	7,2	120	128,5	17	78,5	25	96	30, 32, 35, 40
C 725	725	1.530	1.600	2,4	1	1	175	270	10,5	140	138,5	23	78,5	30	115	42, 45, 50
C 830	828	1.755	1.500	4	1	1	201	381	12	160	138,5	23	78,5	30	115	42, 45, 50
C 1370	1.370	3.340	1.300	3	1	0,8	383	530	16	163	170	23	110	30	115	42, 45, 50
C 1580	1.580	3.845	1.200	4	1	0,8	441	835	19,5	183	178	24	110	34	120	50, 55, 60
C 2390	2.390	5.855	1.100	3,2	1	0,7	671	1.195	27	183	207	30	127	40	155	60, 65, 70
C 2700	2.700	6.600	1.000	4,4	1	0,5	756	1.600	30,5	203	207	30	127	40	155	60, 65, 70
C 5620	5.620	15.050	900	5,4	2	0,3	1.725	4.250	51,5	250	240	31	152	44	170	70, 75, 80
C 7040	7.040	18.840	800	6,6	2	0,3	2.159	8.900	75,5	300	252	30	152	50	185	80, 85, 90

Order Example 1: C 70.33 Ø20 Ø25 Order Example 2: C 320.33 Ø30 Ø30

C 320	33	Ø30 Ø30
Type Semiflex® Compact Plus C 320	both sides locking-assembly	bore diameters

To ensure the correct selection of the Semiflex® please use the TD Calculator of the column Semiflex® or please use our selection procedure and legend area to download the required information.

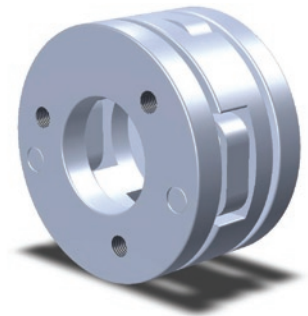
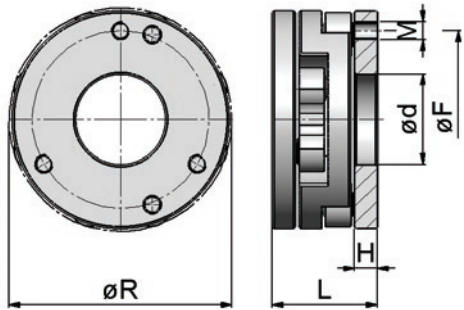

Hub version 5: flange-mounting

	T_{Kv} (Nm)	T_{Kmax} (Nm)	n_{max} (1/min)	ΔK_t (mm)	ΔK_a (mm)	ΔK_w (°)	C_T (kNm/rad)	J (kg cm ²)	m (kg)	ØR (mm)	L (mm)	H (mm)	ØF (mm)	M
C 70	69	112	3.400	1	1	1	13	5	0,7	72	35	8	56	3xM6
C 230	230	460	2.300	1,6	1	1	53	22	1,8	94	58	12,5	70	3xM10
C 265	265	530	2.200	1,6	1	1	61	34	2,2	104	58	12,5	70	3xM10
C 320	316	635	2.000	3	1	1	73	68	3,1	124	58	12,5	98	3xM10
C 575	575	1.220	1.700	2,4	1	1	140	99	4,8	120	78,5	17	90	3xM16
C 725	725	1.530	1.600	2,4	1	1	175	187	6,5	140	78,5	17	110	3xM16
C 830	828	1.755	1.500	4	1	1	201	292	7,6	160	78,5	17	120	3xM16
C 1370	1.370	3.340	1.300	3	1	0,8	383	434	12	163	110	26	120	3xM20
C 1580	1.580	3.845	1.200	4	1	0,8	441	703	15	183	110	26	140	3xM20
C 2390	2.390	5.855	1.100	3,2	1	0,7	671	851	18	183	127	31	135	5xM20
C 2700	2.700	6.600	1.000	4,4	1	0,5	756	1.299	22	203	127	31	150	5xM20
C 5620	5.620	15.050	900	5,4	2	0,3	1.725	3.499	37	250	152	33	200	5xM24
C 7040	7.040	18.840	800	6,6	2	0,3	2.159	7.064	47	300	152	33	250	5xM24

Order Example 1: C 70.55 Order Example 2: C 575.55

C 575	55
Type Semiflex® Compact Plus C 575	both sides flange-mounting

To ensure the correct selection of the Semiflex® please use the TD Calculator of the column Semiflex® or please use our selection procedure and legend area to download the required information.

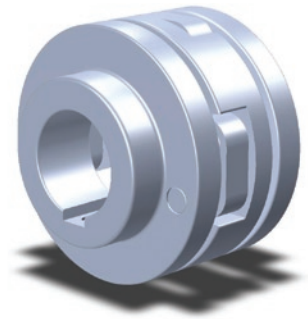
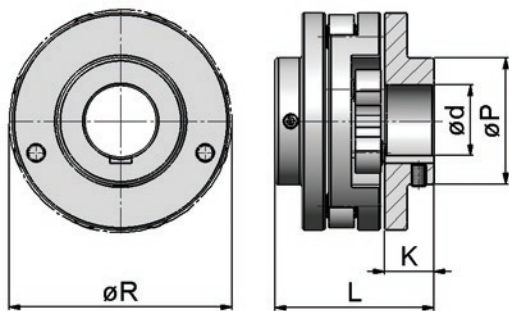

Hub version 6: standard hub

	T_{KN} (Nm)	T_{Kmax} (Nm)	n_{max} (1/min)	ΔK_r (mm)	ΔK_a (mm)	ΔK_w (°)	C_r (kNm/rad)	J (kg cm ²)	m (kg)	$\varnothing R$ (mm)	L (mm)	$\varnothing d_{max}$ (mm)	$\varnothing P$ (mm)	K (mm)
C 70	69	112	3.400	1	1	1	13	8,9	1,1	72	59	40	70	20
C 230	230	460	2.300	1,6	1	1	53	25,4	2,3	94	88	40	56	27,5
C 265	265	530	2.200	1,6	1	1	61	37,2	2,6	104	88	50	65	27,5
C 320	316	635	2.000	3	1	1	73	73,9	3,5	124	88	50	70	27,5
C 575	575	1.220	1.700	2,4	1	1	140	108	6,6	120	120,5	45	70	38
C 725	725	1.530	1.600	2,4	1	1	175	205	7,7	140	126,5	55	85	41
C 830	828	1.755	1.500	4	1	1	201	324	9,5	160	140,5	60	90	48
C 1370	1.370	3.340	1.300	3	1	0,8	383	460	13	163	146	60	90	44
C 1580	1.580	3.845	1.200	4	1	0,8	441	755	17	183	158	60	90	50
C 2390	2.390	5.855	1.100	3,2	1	0,7	671	910	20	183	167	60	90	51
C 2700	2.700	6.600	1.000	4,4	1	0,5	756	1.340	24	203	177	65	95	56
C 5620	5.620	15.050	900	5,4	2	0,3	1.725	3.800	43,5	250	222	80	120	68
C 7040	7.040	18.840	800	6,6	2	0,3	2.159	8.550	71,5	300	278	100	160	96

Order Example 1: C 70.66 Ø25 Ø25 Order Example 2: C 320.66 Ø38 Ø40

C 320	66	Ø38 Ø40
Type Semiflex® Compact Plus C 320	both sides standard hub	bore diameters

To ensure the correct selection of the Semiflex® please use the TD Calculator of the column Semiflex® or please use our selection procedure and legend area to download the required information.

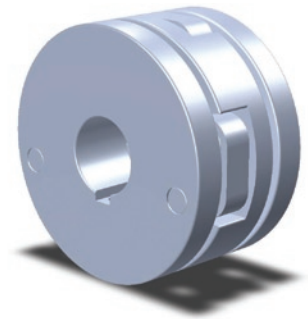
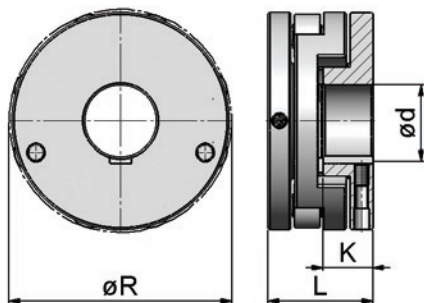

Hub version 7: internal hub

	T_{kin} (Nm)	$T_{\text{K,max}}$ (Nm)	n_{max} (1/min)	ΔK_r (mm)	ΔK_a (mm)	ΔK_{vr} (°)	C_t (kNm/rad)	J (kg cm ²)	m (kg)	$\varnothing R$ (mm)	L (mm)	K (mm)	$\varnothing d_{\text{max}}$ (mm)
C 230	230	460	2.300	1,6	1	1	53	24,3	2,2	94	58	27,5	25
C 265	265	530	2.200	1,6	1	1	61	36,6	2,7	104	58	27,5	35
C 320	316	635	2.000	3	1	1	73	72,9	3,5	124	58	27,5	45
C 575	575	1.220	1.700	2,4	1	1	140	104	5,4	120	78,5	38	30
C 1370	1.370	3.340	1.300	3	1	0,8	383	455	13,5	163	110	44	40
C 1580	1.580	3.845	1.200	4	1	0,8	441	745	16,5	183	110	50	60
C 2700	2.700	6.600	1.000	4,4	1	0,5	756	1.330	23,5	203	127	56	70
C 5620	5.620	15.050	900	5,4	2	0,3	1.725	3.775	42	250	152	68	90

Order Example 1: C 265.77 $\varnothing 25$ $\varnothing 25$ Order Example 2: C 725.77 $\varnothing 35$ $\varnothing 35$

C 725	77	$\varnothing 35$ $\varnothing 35$
Type Semiflex® Compact Plus C 725	both sides internal hub	bore diameters

To ensure the correct selection of the Semiflex® please use the TD Calculator of the column Semiflex® or please use our selection procedure and legend area to download the required information.

1. Calculation of the design torque. Please multiply your continuous torque by the required performance factor (table 1) and the required service factor (table 2) to get the design torque.

An alternative:

simply use under www.schmidt-kupplung.com the

TD Calculator of the column Semiflex®

5. Make sure that the misalignment capability is sufficient. There is a trade-off between the radial, axial and angular misalignment capabilities. Be certain that the combined percentages of each do not exceed 100%.

Table 1: performance factor

speed range 1/min	service life (h)	performance factor
0-500	5.000	1,8
0-500	10.000	2,3
0-500	20.000	2,8
500-1.000	5.000	2,3
500-1.000	10.000	2,8
500-1.000	20.000	3,5
1.000-2.000	5.000	2,8
1.000-2.000	10.000	3,6
1.000-2.000	20.000	4,4
2.000-3.000	5.000	3,2
2.000-3.000	10.000	4
2.000-3.000	20.000	4,8

Table 2: service factor

uniform	1
light shocks	1,5
medium shocks	2
heavy shocks	2,5

2. Select a coupling size that has a continuous torque rating greater than your calculated design torque.
3. Make sure that the peak torque of the application does not exceed the maximum torque rating of the coupling.
4. Please check the coupling maximum speed to be sure it is within the rated maximum speed.

Legend

Performance

T_{KN}	continuous torque rating of the coupling (Nm)
$T_{K\ max}$	maximum torque capacity of the coupling (Nm)
n_{max}	maximum speed of the coupling (1/min)
ΔK_r	maximum radial misalignment capacity (mm)
ΔK_a	maximum axial misalignment capacity (mm)
ΔK_w	maximum angular misalignment capacity (°)
C_T	torsional stiffness (kNm/rad)
J	moment of inertia (kg cm ²)
m	weight of the coupling (kg)

Dimension

$\varnothing R$	swing diameter (mm)
H	disc thickness (mm)
L	coupling length (mm)
$\varnothing P$	hub diameter (mm)
K	total hub length (mm)
X	mounting space (mm)
W	coupling basis (mm)
$\varnothing F$	bolt circle diameter (mm)
M	number of threaded bores x bolt size
$\varnothing d$	bore diameter (mm)

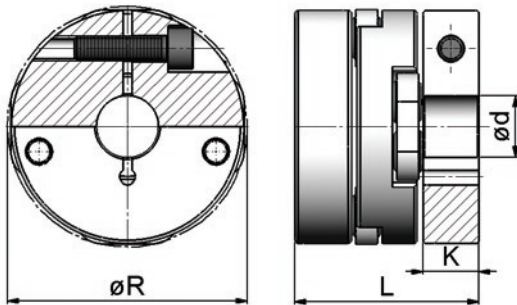

Hub version 1: clamp hub

	T_{KN} (Nm)	T_{Kmax} (Nm)	n_{max} (1/min)	ΔK_r (mm)	ΔK_a (mm)	ΔK_w (°)	C_r (kNm/rad)	J (kg cm ²)	m (kg)	$\varnothing R$ (mm)	L (mm)	K (mm)	$\varnothing d_{max}$ (mm)
D 40	40	80	2.500	1,2	0,5	1	9	1,2	0,3	61,5	52	12	30
D 45	40	80	2.500	1,2	0,5	1	9	1,3	0,3	61,5	58	15	25
D 180	180	300	5.000	1,5	0,5	0,5	34	5,1	0,6	77	59	18	35
D 185	180	300	5.000	1,5	0,5	0,5	34	5	0,6	77	67	18	35

Order Example 1: D 45.11 Ø25 Ø25 Order Example 2: D 180.11 Ø30 Ø30

D 180	11	Ø30 Ø30
Type Semiflex® Dynamic D 180	both sides clamp hub	bore diameters

To ensure the correct selection of the Semiflex® please use the TD Calculator of the column Semiflex® or please use our selection procedure and legend area to download the required information.

1. Calculation of the design torque. Please multiply your continuous torque by the required performance factor (table 1) and the required service factor (table 2) to get the design torque.

An alternative:

simply use under www.schmidt-kupplung.com the

TD Calculator of the column Semiflex®

5. Make sure that the misalignment capability is sufficient. There is a trade-off between the radial, axial and angular misalignment capabilities. Be certain that the combined percentages of each do not exceed 100%.

Table 1: performance factor

speed range 1/min	service life (h)	performance factor
0-500	5.000	1,8
0-500	10.000	2,3
0-500	20.000	2,8
500-1.000	5.000	2,3
500-1.000	10.000	2,8
500-1.000	20.000	3,5
1.000-2.000	5.000	2,8
1.000-2.000	10.000	3,6
1.000-2.000	20.000	4,4
2.000-3.000	5.000	3,2
2.000-3.000	10.000	4
2.000-3.000	20.000	4,8

Table 2: service factor

uniform	1
light shocks	1,5
medium shocks	2
heavy shocks	2,5

2. Select a coupling size that has a continuous torque rating greater than your calculated design torque.
3. Make sure that the peak torque of the application does not exceed the maximum torque rating of the coupling.
4. Please check the coupling maximum speed to be sure it is within the rated maximum speed.

Legend

Performance

T_{KN}	continuous torque rating of the coupling (Nm)
$T_{K\ max}$	maximum torque capacity of the coupling (Nm)
n_{max}	maximum speed of the coupling (1/min)
ΔK_r	maximum radial misalignment capacity (mm)
ΔK_a	maximum axial misalignment capacity (mm)
ΔK_w	maximum angular misalignment capacity (°)
C_T	torsional stiffness (kNm/rad)
J	moment of inertia (kg cm ²)
m	weight of the coupling (kg)

Dimension

$\varnothing R$	swing diameter (mm)
H	disc thickness (mm)
L	coupling length (mm)
$\varnothing P$	hub diameter (mm)
K	total hub length (mm)
X	mounting space (mm)
W	coupling basis (mm)
$\varnothing F$	bolt circle diameter (mm)
M	number of threaded bores x bolt size
$\varnothing d$	bore diameter (mm)