

**Flexible
claw couplings
ELKU-N**

KWN 22013

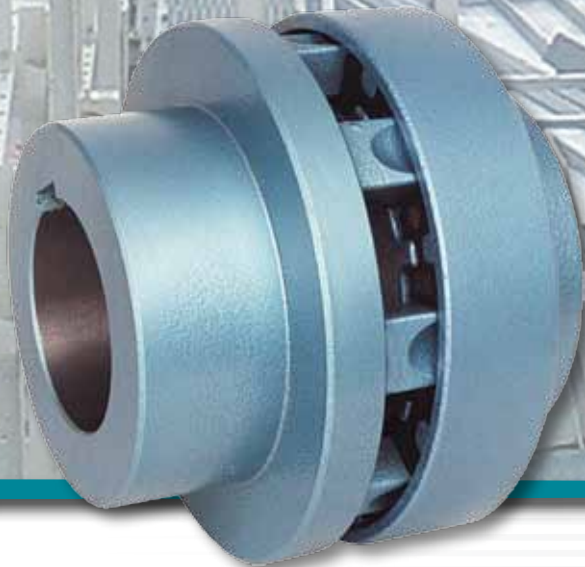

**Couplings from
Dresden/Germany
By specialists – for specialists**

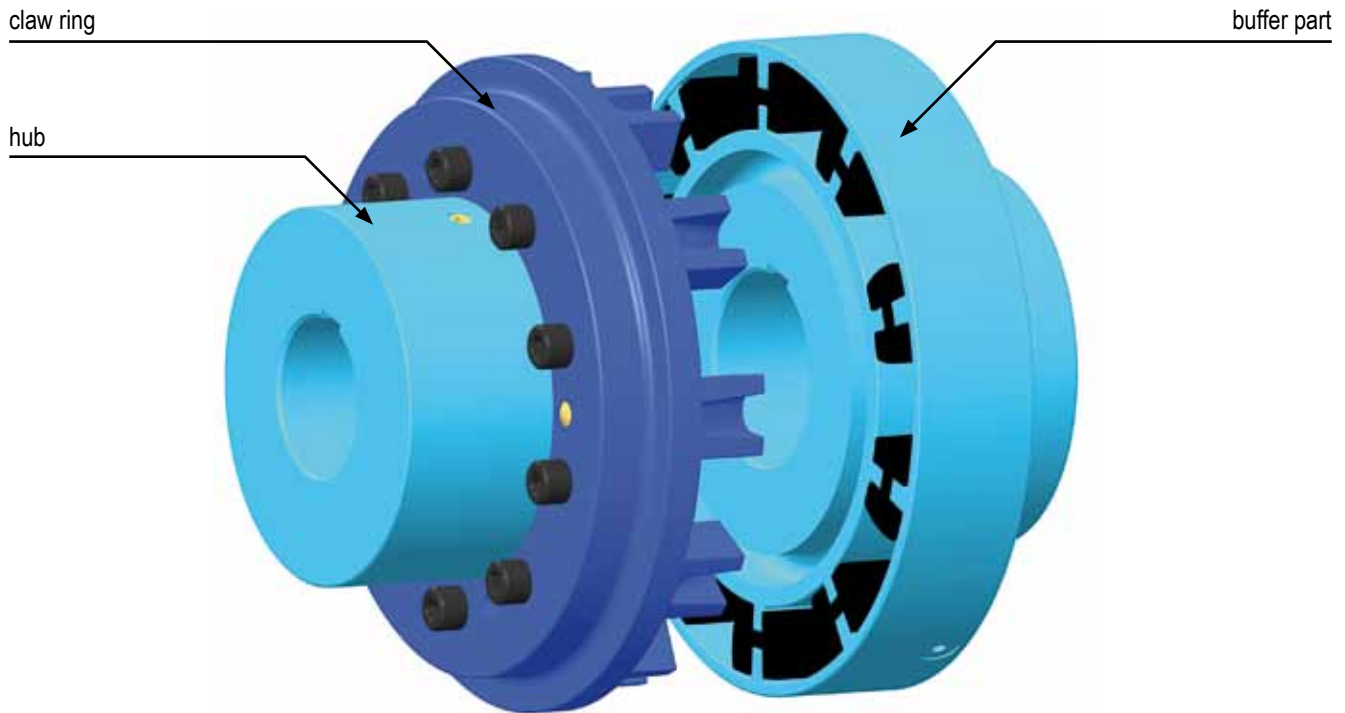

technical features

The flexible claw coupling N (ELKU-N) is a positive-locking, torsionally flexible coupling which allows radial, axial and angular displacement between the driving and the driven shafts. It is a fail-safe coupling.

The torque will be transmitted by the flexible buffer set fitted in the buffer part and distributed symmetrical around the circumference of the coupling.

The claws of the claw ring (type A) or claw part (type B) are operating in the space between the buffers.

The buffers are subjected to compression. That's why there's a low wear and high loading capacity.

The high damping of the coupling protects the drive from excessive dynamic overloading. The progressively rising spring characteristic allows a rapid reduction of energy oscillations and limits their amplitude.

Perfect operation can be guaranteed at a working temperature of - 30 °C to + 60 °C.

The standard hub material is grey cast iron EN-GJL-250-DIN EN 1561.1561.

types

type	A	three parts design
type	B	two parts design
type	S1	design with brake disk
type	S2	design with radial dismountable brake disk
type	H	design with spacer

we also offer special designs

- design for vertical fitting
- design for explosive surroundings

 II 2 G IIB T5 - 20 °C ≤ T_a ≤ 50 °C
 II 2 D 90 °C - 20 °C ≤ T_a ≤ 50 °C

- design of claw couplings according to KWN 22003
- other designs on request

Technical changes for the purpose of progress are reserved. The design may differ from pictorial representation; dimensions have to be complying with given ones.

Table 1

Recommended values for influence factors

temperature factor	S_{ϑ}	numerical values for perbunan			
		S_{ϑ}	1	1	1
°C von	bis	-30	+30	+40	+60
		+30	+40	+60	+80

starting factor	S_Z	number of starts per hour			
		number of starts per hour	100	200	400
S_Z		1,0	1,2	1,4	1,6

over 800 starts per hour please request

impact factor	S_A or S_L	S_A or S_L		
		slight impacts		1,5
medium impacts			1,8	
high impacts			2,2	

calculation example

Coupling ELKU-N searched for steady drive.

Driving machine:

AC motor type 315 L - 200 kW -1 485 rpm, shaft diameter 80 mm

$$T_{AN} = 9\,550 \cdot \frac{P_{AN}}{n_{AN}} = 9\,550 \cdot \frac{200}{1\,485} = 1\,287 \text{ Nm}$$

quantity Z = 40 per hour - ambient temperature $\vartheta = +40 \text{ }^{\circ}\text{C}$
 starting torque $T_{AS} \approx 2T_{AN} = 2\,574 \text{ Nm}$

Working machine:

centrifugal pump with a relatively low mass inertia

average load torque $T_{LN} = 1\,150 \text{ Nm}$

impact of the rated torque

$$T_{KN} \geq T_{LN} \cdot S_{\vartheta} = 1\,150 \text{ Nm} \cdot 1 = 1\,150 \text{ Nm}$$

according to the rated torque is the ELKU-N coupling size 250 in question for $T_{KN} = 2\,500 \text{ Nm}$ and $T_{Kmax} = 5\,000 \text{ Nm}$.

Check for T_{Kmax} factors:

starting factor: $S_Z = 1$
 temperature factor: $S_{\vartheta} = 1$
 impact factor: $S_A = 1,5$

$$T_{Kmax} \geq T_{AS} \cdot S_Z \cdot S_{\vartheta} \cdot S_A = 2\,574 \text{ Nm} \cdot 1 \cdot 1 \cdot 1,5 = 3\,861 \text{ Nm}$$

This example shows a coupling selection by a simplified calculation. For a professional coupling selection and sizing our technical staff is available for the customer.

T_{AN} : installation torque [Nm]

T_{KN} : coupling torque [Nm]

T_{LN} : load torque [Nm]

T_{Kmax} : max. coupling torque [Nm]

P_{AN} : power [kW]

n_{AN} : input speed [rpm]

Z: starting frequency

ϑ : ambient temperature [$^{\circ}\text{C}$]

- 1) finished bore to ISO-fit H7, keyway to DIN 6885 sheet 1, fit JS 9
- 2) without keyway, pilot bore - untoleranced dimension, „average“ to DIN ISO 2768
- 3) see page 14
- 4) see page 14 „type of hub bore“

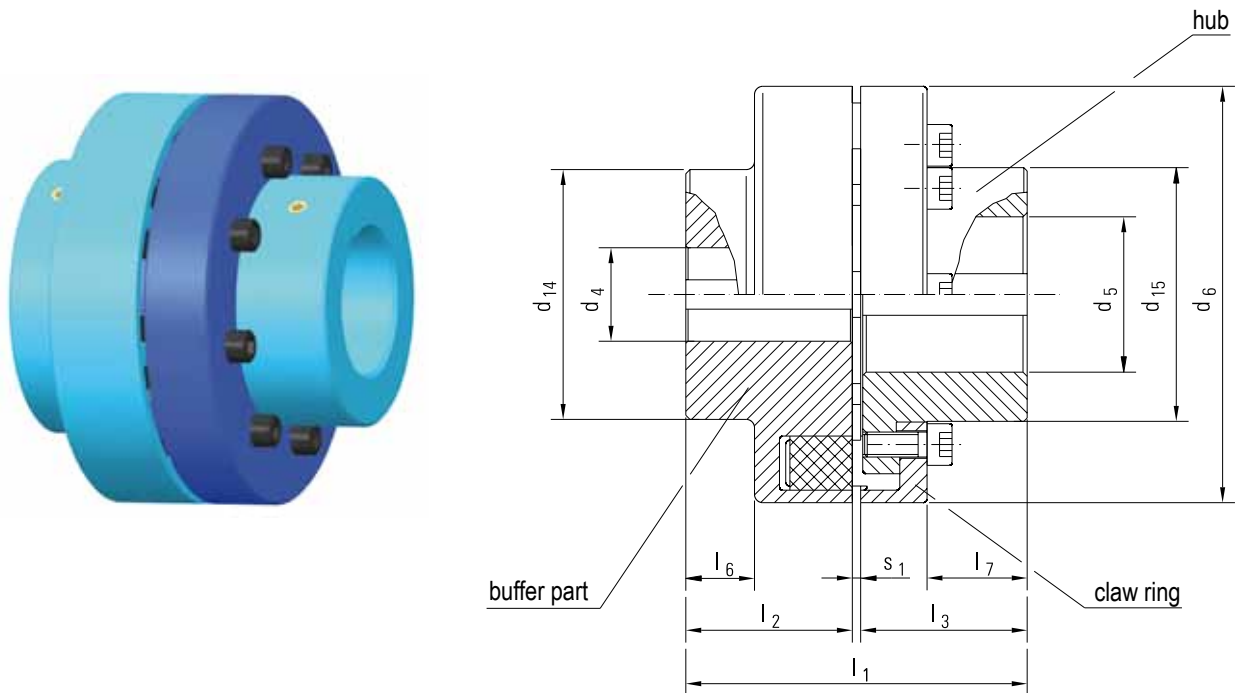

Ordering example: ELKU-N A 250 - 48 H7P1⁴⁾ (x100)³⁾ - 50 H7P1⁴⁾ (x100)³⁾ KWN 22013

Designation of a flexible claw coupling type A, nominal size 250,
 finished bore $d_4 = 48$ mm, bore tolerance H7 with one keyway (hub length $l_2 = 100$ mm),
 finished bore $d_5 = 50$ mm, bore tolerance H7 with one keyway (hub length $l_3 = 100$ mm)

Footnotes see page 3

main dimensions													Table 2		
size	pilot bore ²⁾	d_4 finished bore ¹⁾		pilot bore ²⁾	d_5 finished bore ¹⁾		d_6	d_{14}	d_{15}	l_1	l_2	l_3	l_6	l_7	s_1
		min	max		min	max									
16	-	14	48	-	14	38	110	78	62	82	40	40	13	20	2
25	-	15	55	-	15	45	125	90	75	102	50	50	19	27	2
40	-	18	60	-	18	50	140	98	82	112	55	55	21	27	2
63	-	22	65	-	22	58	160	108	95	122	60	60	21	32	2
100	-	24	75	-	24	65	180	125	108	142	70	70	28	40	2
160	-	28	85	-	28	75	200	140	122	162	80	80	33	48	2
200	-	38	90	-	24	85	225	150	138	182	90	90	38	52	2
250	44	48	100	30	32	95	250	165	155	203	100	100	40	58	3
400	47	55	110	52	55	105	280	180	172	223	110	110	45	68	3
500	47	60	100	44	48	100	315	165	165	253	125	125	55	78	3
	88	105	120	88	105	120		200	200						
630	59	65	110	59	65	110	350	180	180	283	140	140	66	89	3
	88	115	140	88	115	140		230	230						
1 000	64	70	120	64	70	120	400	200	200	323	160	160	82	104	3
	98	125	150	98	125	150		250	250						
1 250	78	80	130	78	80	130	440	215	215	365	180	180	94	116	5
	118	135	160	118	135	160		240	240						
1 600	88	90	145	88	90	145	480	240	240	385	190	190	100	125	5
	134	150	180	134	150	180		300	300						
2 500	98	100	150	98	100	150	520	250	250	425	210	210	108	142	5
	138	155	190	138	155	190		315	315						
3 150	118	120	200	118	120	200	560	320	320	449	220	220	105	140	6
4 000	128	130	220	128	130	220	610	352	352	489	240	240	119	152	6
5 000	138	140	240	138	140	240	660	384	384	529	260	260	128	164	6
6 300	138	140	260	138	140	260	710	416	416	589	290	290	152	188	6

Table 3

permissible shaft misalignment and alignment dimension

size		16	25	40	63	100	160	200	250	400	500	630	1 000	1 250	1 600	2 500	3 150	4 000	5 000	6 300
dimension s_{min} [mm]		2	2	2	2	2	2	2	3	3	3	3	3	5	5	5	6	6	6	6
dimension s_{max} [mm]		4	4	4	6	6	6	6	8	8	8	8	8	10	10	10	12	12	12	12
perm. axial displacement ΔK_a [mm]		2	2	2	4	4	4	4	5	5	5	5	5	5	5	5	6	6	6	6
	n [rpm]																			
perm. radial displacement ΔK_r [mm] at speed n	500	0,3	0,3	0,4	0,4	0,5	0,5	0,6	0,7	0,7	0,8	0,9	1	1	1	1	1,2	1,3	1,4	1,5
	1 000	0,3	0,3	0,4	0,4	0,4	0,4	0,5	0,5	0,4	0,4	0,5	0,5	0,5	0,5	0,5	0,8	0,9	1	
	1 500	0,3	0,3	0,3	0,3	0,3	0,3	0,3	0,3	0,3	0,3	0,3	0,3	0,4	0,3	0,3				
perm. angular displacement ΔK_w^* [mm] at speed n	2 000	0,2	0,2	0,3	0,2	0,2	0,2	0,3	0,2	0,2	0,2	0,3	0,2							
	2 500	0,2	0,2	0,2	0,2	0,2	0,2	0,2	0,2	0,2	0,2									
	3 000	0,2	0,2	0,2	0,2	0,1	0,2													
	$\geq 3 500$	0,1	0,1	0,1	0,1	0,1														
	n [rpm]																			
perm angular displacement ΔK_w [°] at speed n	500	0,2	0,2	0,2	0,2	0,2	0,2	0,2	0,2	0,2	0,2	0,2	0,1	0,1	0,1	0,1	0,12	0,12	0,12	0,12
	1 000	0,2	0,2	0,2	0,2	0,1	0,1	0,1	0,1	0,1	0,1	0,1	0,1	0,1	0,1	0,1	0,08	0,08	0,09	
	1 500	0,2	0,1	0,1	0,1	0,1	0,1	0,1	0,1	0,1	0,1	0,1	0,1	0,1	0,1	0,1				
	2 000	0,1	0,1	0,1	0,1	0,1	0,1	0,1	0,1	0,1	0,1	0,1	0,1							
	2 500	0,1	0,1	0,1	0,1	0,1	0,1	0,1	0,1	0,1										
	3 000	0,1	0,1	0,1	0,1	0,1	0,1	0,1												
	$\geq 3 500$	0,1	0,1	0,1	0,1	0,1														

axial displacement

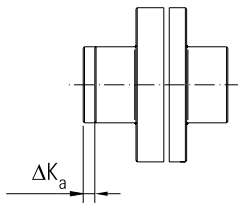

radial displacement

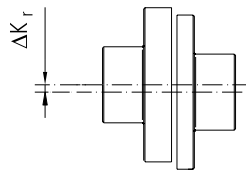

angular displacement

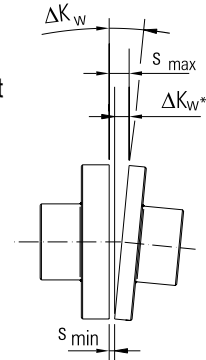
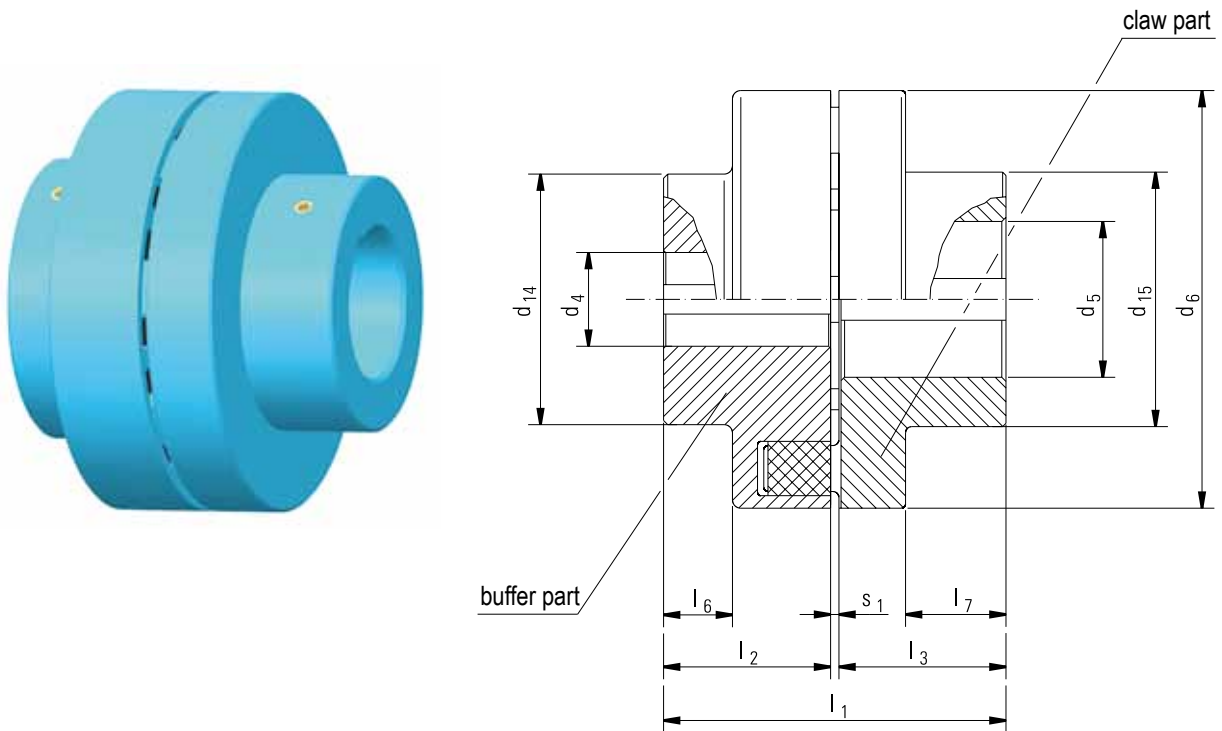

Table 4

characteristic values

size	speed n [rpm]	torque [Nm]			torsion angle φ [°]	dyn. torsional stiffness C_{dyn} [kNm/rad]		rel. damping Ψ [-]	moment of inertia J [kgm ²]		mass m [kg]	
		T_{KN}	T_{Kmax}	$\pm T_{KW}$		at T_{KN}	T_{KN}		$0,5 \cdot T_{KN}$	buffer part	claw ring + hub	buffer part
16	5 000	160	320	40	4,5	12,6	5,8	0,9	0,002	0,002	1,5	1,5
25	5 000	250	500	62	4,5	19,0	8,8	0,9	0,004	0,004	2,5	2,5
40	4 900	400	800	100	4,5	26,0	11,9	0,9	0,007	0,007	3,3	3,4
63	4 250	630	1 260	160	4,5	58,9	27,1	0,9	0,013	0,013	4,7	4,8
100	3 800	1 000	2 000	250	4,5	88,5	40,6	0,9	0,023	0,024	6,9	6,8
160	3 400	1 600	3 200	400	4,5	138,8	63,8	0,9	0,04	0,04	9,5	10
200	3 000	2 000	4 000	500	4,5	236,0	108,4	0,9	0,07	0,08	13	14
250	2 750	2 500	5 000	625	4,5	305,4	140,3	0,9	0,12	0,13	17,5	19,5
400	2 450	4 000	8 000	1 000	4,5	404,3	185,8	0,9	0,2	0,2	24	24
500	2 150	5 000	10 000	1 250	4,5	618,6	284,2	0,9	0,31	0,33	31	32
									0,34	0,37	32	34
630	1 950	6 300	12 600	1 575	4,5	893,7	410,4	0,9	0,54	0,54	43	43
									0,6	0,63	45	47
1 000	1 700	10 000	20 000	2 500	4,5	1 245	572,5	0,9	1,0	0,9	63	59
									1,2	1,0	66	64
1 250	1 550	12 500	25 000	3 125	4,5	1 693	777,6	0,9	1,5	1,5	79	80
									1,7	1,7	82	85
1 600	1 400	16 000	32 000	4 000	4,5	2 122	973,9	0,9	2,3	2,3	100	100
									2,6	2,6	105	110
2 500	1 300	25 000	50 000	6 250	4,5	2 812	1 292	0,9	3,5	3,2	130	120
									3,8	3,6	140	135
3 150	1 200	31 500	63 000	7 300	4,5	3 600	1 500	1,1	5,9	6	180	185
4 000	1 100	40 000	80 000	9 600	4,5	5 000	2 070	1,1	8,6	9,3	225	240
5 000	1 000	50 000	100 000	12 350	4,5	6 800	2 800	1,1	13	14	290	320
6 300	950	63 000	126 000	15 600	4,5	9 300	3 900	1,1	18,5	20	370	400



Ordering example: ELKU-N B 10 - 20 H7P1⁴⁾ (x35)³⁾ - 16 H7P2⁴⁾ (x25) KWN 22013

Designation of a flexible claw coupling type B, nominal size 10
 finished bore $d_4 = 20$ mm, bore tolerance H7 with one keyway in buffer part, (hub length $l_2 = 35$ mm),
 finished bore $d_5 = 16$ mm, bore tolerance H7 and two keyways (120° arranged) in the shortened claw part (hub length $l_3 = 25$ mm)

Footnotes see page 3

main dimensions													Table 5		
size	pilot bore ²⁾	d_4 finished bore ¹⁾		pilot bore ²⁾	d_5 finished bore ¹⁾		d_6	d_{14}	d_{15}	l_1	l_2	l_3	l_6	l_7	s_1
		min	max		min	max									
2,5	-	8	19	-	8	24	58	-	40	42	20	20	-	12	2
4	-	8	24	-	8	28	68	-	46	42	20	20	-	12	2
6,3	-	10	32	-	10	38	80	50	62	62	30	30	9	20	2
10	-	11	42	-	11	42	95	68	70	72	35	35	11	24	2
16	-	14	48	-	14	48	110	78	80	82	40	40	13	26	2
25	-	15	55	-	15	55	125	90	90	102	50	50	19	33	2
40	-	18	60	-	18	60	140	98	98	112	55	55	21	35	2
63	-	22	65	-	22	65	160	108	108	122	60	60	21	40	2
100	-	24	75	-	24	75	180	125	125	142	70	70	28	50	2
160	-	28	85	-	28	85	200	140	140	162	80	80	33	56	2
200	-	38	90	-	38	90	225	150	150	182	90	90	38	72	2
250	44	48	100	30	48	100	250	165	165	203	100	100	40	82	3
400	47	55	110	52	55	110	280	180	180	223	110	110	45	90	3

Table 6 permissible shaft misalignment and alignment dimension

size		2,5	4	6,3	10	16	25	40	63	100	160	200	250	400
dimension s_{\min} [mm]		2	2	2	2	2	2	2	2	2	2	2	3	3
dimension s_{\max} [mm]		4	4	4	4	4	4	4	6	6	6	6	8	8
perm. axial displacement ΔK_a [mm]		2	2	2	2	2	2	2	4	4	4	4	5	5
	n [rpm]													
perm. radial displacement ΔK_r [mm] at speed n	500	0,2	0,2	0,2	0,3	0,3	0,3	0,4	0,4	0,5	0,5	0,6	0,7	0,7
	1 000	0,2	0,2	0,2	0,3	0,3	0,3	0,4	0,4	0,4	0,4	0,5	0,5	0,4
	1 500	0,2	0,2	0,2	0,3	0,3	0,3	0,3	0,3	0,3	0,3	0,3	0,3	0,3
perm. angular displacement ΔK_w^* [mm] at speed n	2 000	0,2	0,2	0,2	0,3	0,2	0,2	0,3	0,2	0,2	0,2	0,3	0,2	0,2
	2 500	0,2	0,2	0,2	0,2	0,2	0,2	0,2	0,2	0,2	0,2	0,2	0,2	0,2
	3 000	0,2	0,2	0,2	0,2	0,2	0,2	0,2	0,2	0,1	0,2	0,2		
	$\geq 3 500$	0,1	0,1	0,1	0,1	0,1	0,1	0,1	0,1	0,1				
	n [rpm]													
perm angular displacement ΔK_w [°] at speed n	500	0,2	0,2	0,2	0,2	0,2	0,2	0,2	0,2	0,2	0,2	0,2	0,2	0,2
	1 000	0,2	0,2	0,2	0,2	0,2	0,2	0,2	0,2	0,1	0,1	0,1	0,1	0,1
	1 500	0,2	0,2	0,2	0,2	0,2	0,1	0,1	0,1	0,1	0,1	0,1	0,1	0,1
	2 000	0,2	0,2	0,2	0,2	0,1	0,1	0,1	0,1	0,1	0,1	0,1	0,1	0,1
	2 500	0,2	0,2	0,2	0,1	0,1	0,1	0,1	0,1	0,1	0,1	0,1	0,1	0,1
	3 000	0,2	0,1	0,2	0,1	0,1	0,1	0,1	0,1	0,1	0,1	0,1		
	$\geq 3 500$	0,1	0,1	0,1	0,1	0,1	0,1	0,1	0,1	0,1				

axial displacement

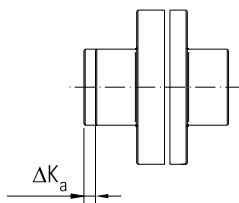

radial displacement

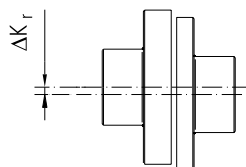

angular displacement

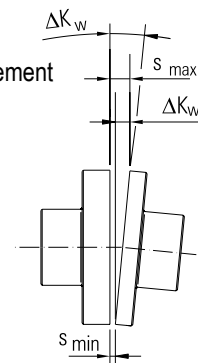
Table 7
characteristic values

size	speed n [rpm]	torque [Nm]			torsion angle	dyn. torsional stiffness C_{dyn} [kNm/rad]		rel. damping	moment of inertia J [kgm ²]		mass m [kg]	
		T_{KN}	T_{Kmax}	$\pm T_{\text{KW}}$	at T_{KN}	T_{KN}	$0,5 \cdot T_{\text{KN}}$	Ψ	buffer part	claw part	buffer part	claw part
2,5	5000	25	50	6	4,5	2,3	0,9	0,9	0,0001	0,0001	0,2	0,2
4	5000	40	80	10	4,5	3,6	1,6	0,9	0,0002	0,0001	0,3	0,3
6,3	5000	63	126	16	4,5	5,4	2,5	0,9	0,0004	0,0004	0,6	0,7
10	5000	100	200	25	4,5	8,3	3,8	0,9	0,0009	0,0008	0,9	1,1
16	5000	160	320	40	4,5	12,6	5,8	0,9	0,002	0,002	1,5	1,6
25	5000	250	500	62	4,5	19,0	8,8	0,9	0,004	0,004	2,5	2,6
40	4900	400	800	100	4,5	26,0	11,9	0,9	0,007	0,007	3,3	3,6
63	4250	630	1260	160	4,5	58,9	27,1	0,9	0,013	0,012	4,7	4,7
100	3800	1000	2000	250	4,5	88,5	40,6	0,9	0,023	0,022	6,9	7,1
160	3400	1600	3200	400	4,5	138,8	63,8	0,9	0,04	0,04	9,5	10,5
200	3000	2000	4000	500	4,5	236,0	108,4	0,9	0,07	0,065	13	11,5
250	2750	2500	5000	625	4,5	305,4	140,3	0,9	0,12	0,11	17,5	16,5
400	2450	4000	8000	1000	4,5	404,3	185,8	0,9	0,2	0,17	24	21

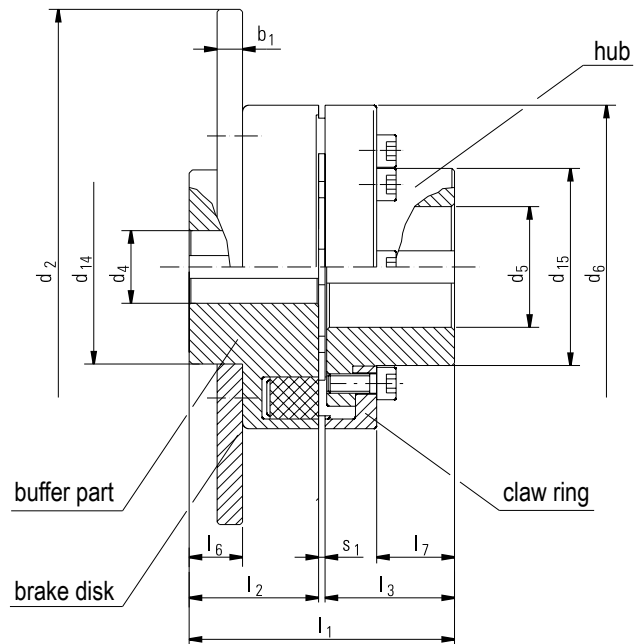
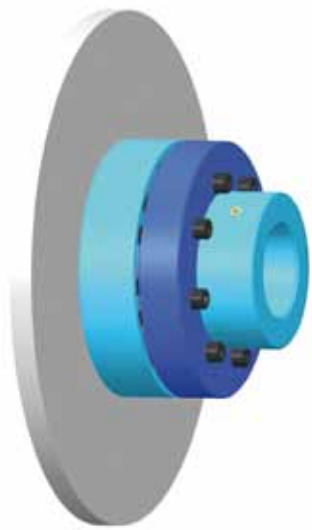

Ordering example: ELKU-N S1 25 - 315 x 16 - 50 H7P1⁴⁾ (x50)³⁾ - 15 H7P1⁴⁾ (x50)³⁾ KWN 22013

Designation of a flexible claw coupling type S1, nominal size 25 with brake disk $d_2 = 315$ mm, $b_1 = 16$ mm, finished bore $d_4 = 50$ mm, bore tolerance H7, with one keyway, (hub length $l_2 = 50$ mm), finished bore $d_5 = 13$ mm, bore tolerance H7, with one keyway, (hub length $l_3 = 50$ mm)

Footnotes see page 3

main dimensions													Table 8				
size	pilot bore ²⁾	d_4 finished bore ¹⁾		d_5 finished bore ¹⁾		d_6	d_{14}	d_{15}	d_2	b_1	l_1	l_2	l_3	l_6	l_7	s_1	
		min	max	min	max												h9
brake torque statically	25	-	15	55	15	45	125	85	75	315	16	102	50	50	19	27	2
	40	-	18	55	18	50	140	85	82	315	16	112	55	55	21	27	2
	63	-	22	65	22	60	160	105	98	355	18	122	60	60	21	32	2
	100	-	24	70	24	65	180	115	108	400	18	142	70	70	28	40	2
	160	-	28	75	28	75	200	120	122	450	20	162	80	80	33	48	2
	200	-	38	75	24	85	225	120	138	450	20	182	90	90	38	52	2
	250	30	48	100	32	95	250	160	155	500	20	203	100	100	40	58	3
	400	52	55	105	55	105	280	170	172	630	30	223	110	110	45	68	3
	500	44	60	100	48	100	315	160	165	560	30	253	125	125	55	78	3
		88	105	120	105	120	315	195	200	710	30	253	125	125	55	78	3
630	59	65	105	65	110	350	170	180	630	30	283	140	140	66	89	3	
	88	110	135	115	140	350	220	230	800	30	283	140	140	66	89	3	
brake torque dynamically	1 000	64	70	120	70	120	400	195	200	710	30	323	160	160	82	104	3
		98	125	135	125	150	400	220	250	800	30	323	160	160	82	104	3
	1 250	78	80	120	80	130	440	195	215	710	30	365	180	180	94	116	5
		118	125	135	135	160	440	220	265	800	30	365	180	180	94	116	5
	1 600	88	90	135	90	145	480	220	240	1 000	30	385	190	190	100	125	5
		134	140	175	145	180	480	280	300	1 120	30	385	190	190	100	125	5
	2 500	98	100	140	90	150	520	230	250	1 000	30	425	210	210	108	142	5
	2 500	138	145	180	155	190	520	295	315	1 120	30	425	210	210	108	142	5
	3 150	118	110	190	120	200	560	300	320	1 000	30	449	220	220	105	140	6
	4 000	128	120	210	130	220	610	332	352	1 250	30	489	240	240	119	152	6
5 000	138	130	230	140	240	660	364	384	1 250	30	529	260	260	128	164	6	
6 300	138	130	250	140	260	710	396	416	1 250	30	589	290	290	152	188	6	

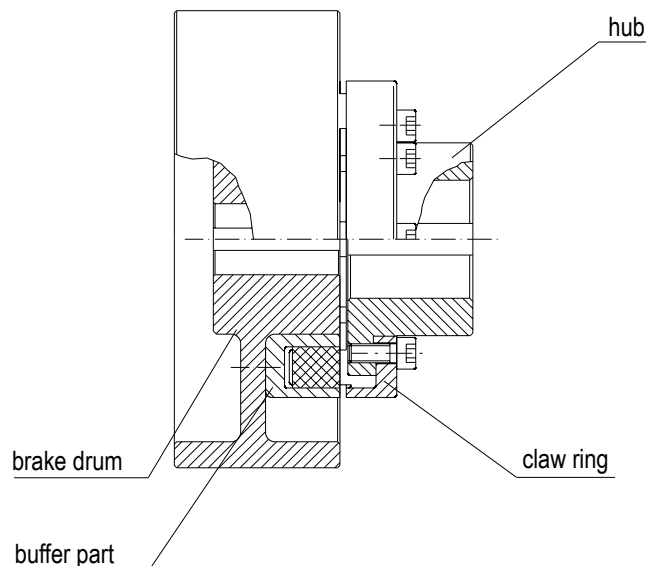
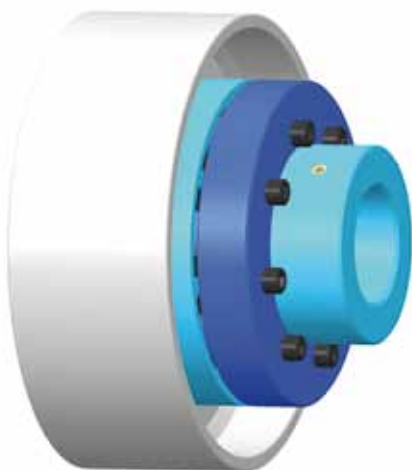

ELKU-N P: flexible claw coupling with brake drum

Table 9

characteristic values

size	speed n [rpm]	torque [Nm]			torsion angle φ [°]	dyn. torsional stiffness C_{dyn} [kNm/rad]		rel. damping Ψ [-]	moment of inertia J [kgm ²]		mass m [kg]	
		T_{KN}	T_{Kmax}	$\pm T_{KW}$		at T_{KN}	T_{KN}		$0,5 \cdot T_{KN}$	buffer part + brake disk	claw ring + hub	buffer part + brake disk
25	4 800	250	500	62	4,5	19,0	8,8	0,9	0,124	0,004	11,4	2,5
40	4 800	400	800	100	4,5	26,0	11,9	0,9	0,127	0,007	12,0	3,4
63	4 250	630	1 260	160	4,5	58,9	27,1	0,9	0,231	0,013	17,3	4,8
100	3 800	1 000	2 000	250	4,5	88,5	40,6	0,9	0,374	0,024	22,7	6,8
160	3 400	1 600	3 200	400	4,5	138,8	63,8	0,9	0,664	0,04	31,5	10
200	3 000	2 000	4 000	500	4,5	236,0	108,4	0,9	0,69	0,08	34,1	14
250	2 750	2 500	5 000	625	4,5	305,4	140,3	0,9	1,07	0,13	44,7	19,5
400	2 400	4 000	8 000	1 000	4,5	404,3	185,8	0,9	3,82	0,2	91,0	24
500	2 150	5 000	10 000	1 250	4,5	618,6	284,2	0,9	2,56	0,33	83,7	32
	2 150	5 000	10 000	1 250	4,5	618,6	284,2	0,9	6,18	0,37	117,5	34
630	1 950	6 300	12 600	1 575	4,5	893,7	410,4	0,9	4,16	0,54	109,5	43
	1 900	6 300	12 600	1 575	4,5	893,7	410,4	0,9	9,99	0,63	152,5	47
1000	1 700	10 000	20 000	2 500	4,5	1 245	572,5	0,9	6,83	0,9	148,2	59
	1 700	10 000	20 000	2 500	4,5	1 245	572,5	0,9	10,5	1,0	168,3	64
1250	1 550	12 500	25 000	3 125	4,5	1 693	777,6	0,9	8,29	1,5	160,4	80
	1 550	12 500	25 000	3 125	4,5	1 693	777,6	0,9	10,9	1,7	178,8	85
1600	1 400	16 000	32 000	4 000	4,5	2 122	973,9	0,9	25,3	2,3	270,0	100
	1 350	16 000	32 000	4 000	4,5	2 122	973,9	0,9	38,6	2,6	315,3	110
2 500	1 300	25 000	50 000	6 250	4,5	2 812	1 292	0,9	26,5	3,2	300,0	120
2 500	1 200	25 000	50 000	6 250	4,5	2 812	1 292	0,9	40,1	3,6	355,0	135
3 150	1 200	31 500	63 000	7 300	4,5	3 600	1 500	1,1	28,9	6,0	350,0	185
4 000	1 100	40 000	80 000	9 600	4,5	5 000	2 070	1,1	64,6	9,3	490,0	240
5 000	1 000	50 000	100 000	12 350	4,5	6 800	2 800	1,1	69,0	14,0	555,0	320
6 300	950	63 000	126 000	15 600	4,5	9 300	3 900	1,1	74,5	20,0	635,0	400

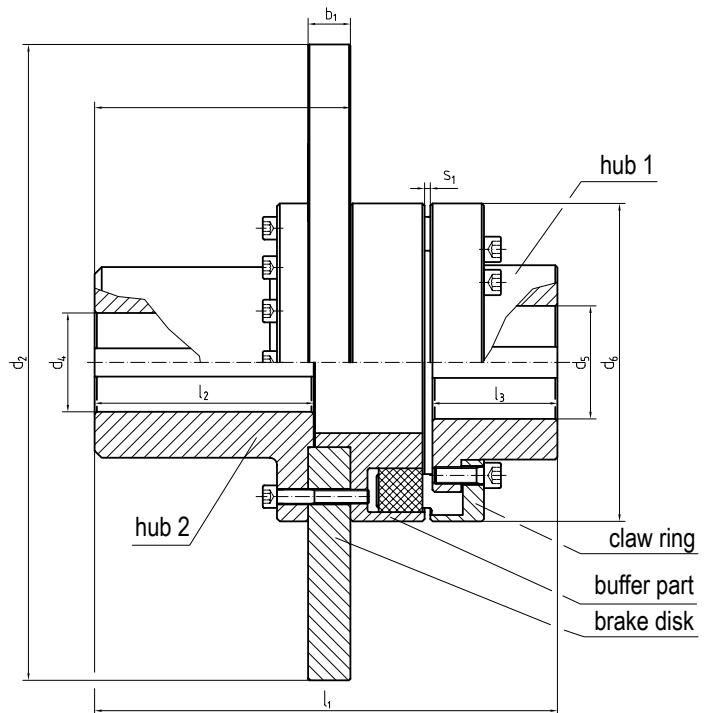
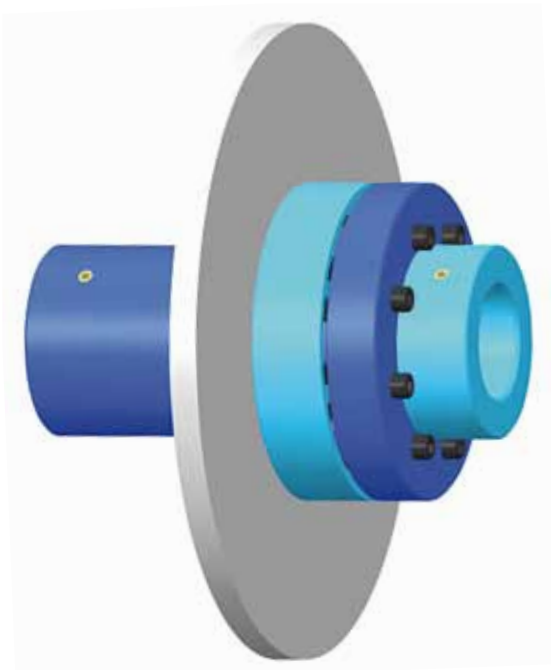

ELKU-N S2: flexible claw coupling with brake disk, five parts

Ordering example: ELKU-N S2 25 - 315 x 30 - 50 H7P1⁴) (x110)³ - 15 H7P1⁴) (x50)³ KWN 22013

Designation of a flexible claw coupling type S2, nominal size 25, with brake disk $d_2 = 315$ mm, $b_1 = 30$ mm, finished bore $d_4 = 50$ mm, bore tolerance H7 with one keyway, (hub length $l_2 = 110$ mm), finished bore $d_5 = 15$ mm, bore tolerance H7 with one keyway, (hub length $l_3 = 50$ mm)

Footnotes see page 3

main dimensions										Table 10		
size	d_4 finished bore ¹⁾		d_5 finished bore ¹⁾		d_6 h9	d_2	b_1	l_1	l_2	l_3	l_6	s_1
	max	min	max	max								
25	55	15	45	125	315	30	222	110	50	138	3	
40	60	18	50	140	315	30	260	140	55	168	3	
63	65	22	60	160	315	30	270	140	60	167	4	
100	75	24	65	180	355	30	283	140	70	167	4	
160	85	28	75	200	400	30	328	170	80	197	4	
200	90	24	85	225	450	30	343	170	90	197	4	
250	100	32	95	250	500	30	402	210	100	236	6	
400	110	55	105	280	560	30	417	210	110	236	6	
500	120	48	100	315	630	30	437	210	125	236	6	
	120	105	120	315	630	30	452	210	140	236	6	
630	140	65	110	350	710	30	456	210	140	236	6	
	140	115	140	350	710	30	456	210	140	236	6	

For special demands of torque transmission we are able to propose further solutions.

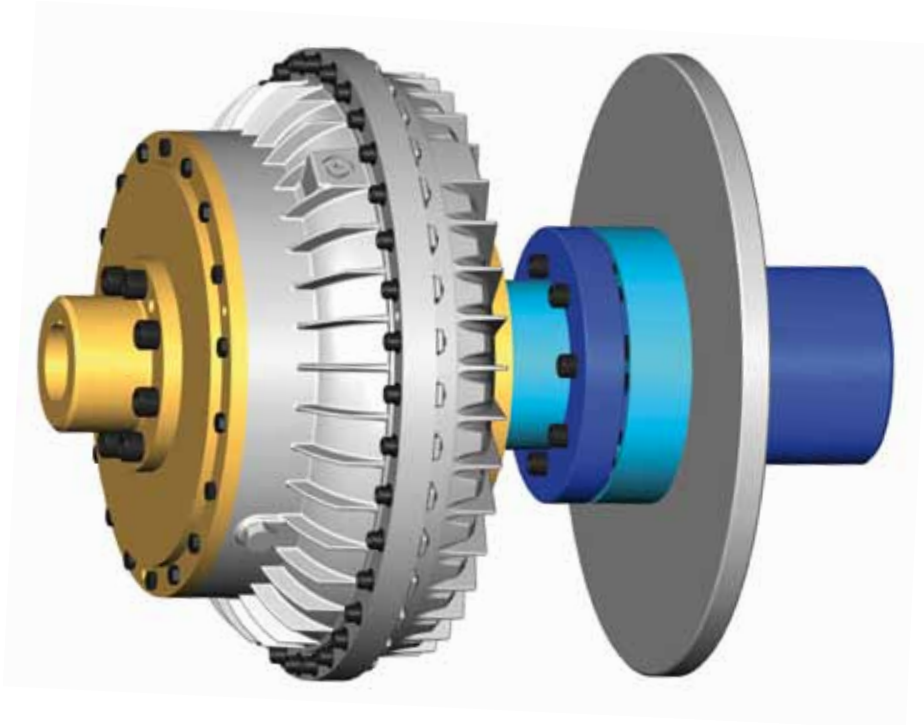

ELKU-N S2: flexible claw coupling as connecting coupling for hydrodynamically coupling TK-N S

Table 11		characteristic values										
size	speed n [rpm]	torque [Nm]			torsion angle φ [°] at T_{KN}	dyn. torsional stiffness C_{dyn} [kNm/rad]		rel. damping Ψ [-]	moment of inertia J [kgm ²]		mass m [kg]	
		T_{KN}	T_{Kmax}	$\pm T_{KW}$		T_{KN}	$0,5 \cdot T_{KN}$		buffer part + BS + hub	claw ring + hub	buffer part + BS + hub	claw ring + hub
25	3 400	250	500	62	4,5	19,0	8,8	0,9	0,2	0,004	22	2,5
40	2 750	400	800	100	4,5	26,0	11,9	0,9	0,25	0,007	26,5	3,4
63	2 750	630	1 260	160	4,5	58,9	27,1	0,9	0,26	0,013	29,5	4,8
100	2 150	1 000	2 000	250	4,5	88,5	40,6	0,9	0,4	0,024	35	6,8
160	2 150	1 600	3 200	400	4,5	138,8	63,8	0,9	0,68	0,04	53	10
200	1 700	2 000	4 000	500	4,5	236,0	108,4	0,9	1,1	0,08	63	14
250	1 400	2 500	5 000	625	4,5	305,4	140,3	0,9	1,65	0,13	83	19,5
400	1 100	4 000	8 000	1 000	4,5	404,3	185,8	0,9	2,75	0,2	117	24
500	1 100	5 000	10 000	1 250	4,5	618,6	284,2	0,9	4,2	0,33	138	32
	1 100	5 000	10 000	1 250	4,5	618,6	284,2	0,9	4,2	0,37	138	34
500	950	5 000	10 000	1 250	4,5	618,6	284,2	0,9	4,25	0,33	145	32
	950	5 000	10 000	1 250	4,5	618,6	284,2	0,9	4,25	0,37	145	34
630	1 100	6 300	12 600	1 575	4,5	893,7	410,4	0,9	7,2	0,54	195	43
	1 100	6 300	12 600	1 575	4,5	893,7	410,4	0,9	7,2	0,63	195	47
630	950	6 300	12 600	1 575	4,5	893,7	410,4	0,9	7,3	0,54	205	43
	950	6 300	12 600	1 575	4,5	893,7	410,4	0,9	7,3	0,63	205	47

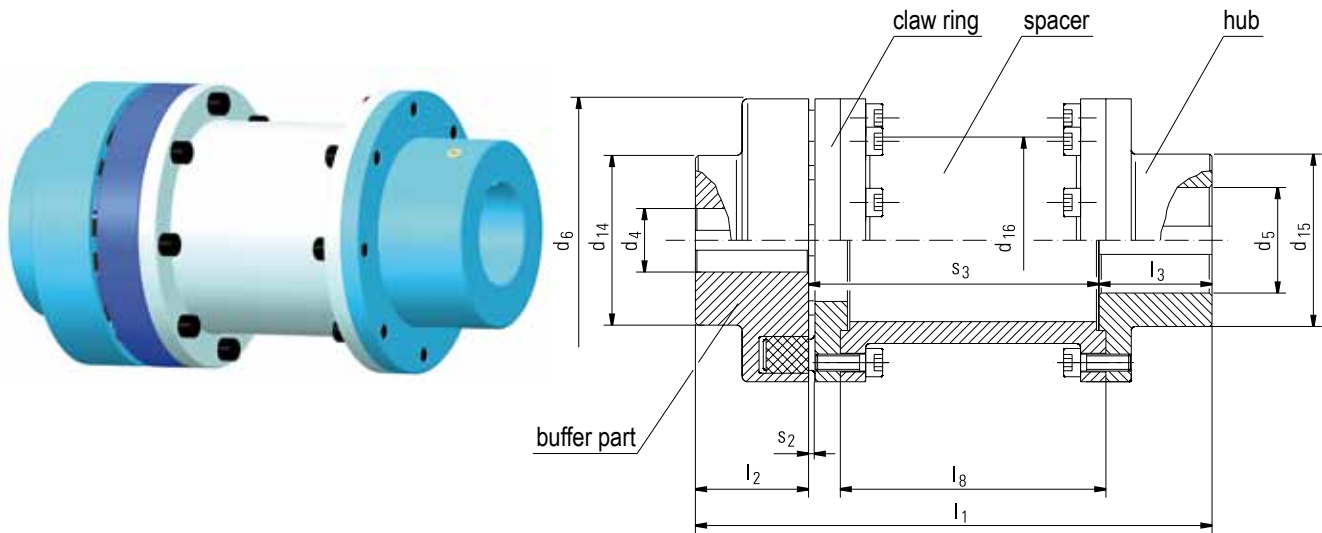

Ordering example: ELKU-N H 63 - 140 - 40 H7P1⁴⁾ (x60)³⁾ - 22 H7P1⁴⁾ (x70)³⁾ KWN 22013

Designation of a flexible claw coupling type H, nominal size 63 with spacer $s_3 = 140$ mm, finished bore $d_4 = 40$ mm, bore tolerance H7, with one keyway, (hub length $l_2 = 60$ mm), finished bore $d_5 = 22$ mm, bore tolerance H7, with one keyway, (hub length $l_3 = 70$ mm)

Footnotes see page 3

main dimensions												Table 12			
size	pilot bore ²⁾	d_4 finished bore ¹⁾		d_5 finished bore ¹⁾		d_6	d_{14}	d_{15}	d_{16}	l_1	l_2	l_3	l_8	s_2	s_3
		min	max	min	max										
6,3	-	10	32	10	32	80	50	50	51	175	30	45	87	5	100
6,3	-	10	32	10	32	80	50	50	51	215	30	45	127	5	140
10	-	11	42	11	42	95	68	70	63	180	35	45	87	5	100
10	-	11	42	11	42	95	68	70	63	220	35	45	127	5	140
16	-	14	48	14	48	110	78	80	73	190	40	50	85	5	100
16	-	14	48	14	48	110	78	80	73	230	40	50	125	5	140
16	-	14	48	14	48	110	78	80	73	280	40	60	165	5	180
25	-	15	55	15	55	125	90	90	85	200	50	50	85	5	100
25	-	15	55	15	55	125	90	90	85	240	50	50	125	5	140
25	-	15	55	15	55	125	90	90	85	290	50	60	165	5	180
25	-	15	55	15	55	125	90	90	85	320	50	70	185	5	200
25	-	15	55	15	55	125	90	90	85	380	50	80	235	5	250
40	-	18	60	18	60	140	98	98	91	220	55	65	82	5	100
40	-	18	60	18	60	140	98	98	91	260	55	65	122	5	140
40	-	18	60	18	60	140	98	98	91	300	55	65	162	5	180
40	-	18	60	18	60	140	98	98	91	320	55	65	182	5	200
40	-	18	60	18	60	140	98	98	91	385	55	80	232	5	250
63	-	22	65	22	65	160	108	108	111	230	60	70	81,5	6	100
63	-	22	65	22	65	160	108	108	111	270	60	70	121,5	6	140
63	-	22	65	22	65	160	108	108	111	310	60	70	161,5	6	180
63	-	22	65	22	65	160	108	108	111	330	60	70	181,5	6	200
63	-	22	65	22	65	160	108	108	111	390	60	80	231,5	6	250
100	-	24	75	24	75	180	125	125	131	290	70	80	121,5	6	140
100	-	24	75	24	75	180	125	125	131	330	70	80	161,5	6	180
100	-	24	75	24	75	180	125	125	131	350	70	80	181,5	6	200
100	-	24	75	24	75	180	125	125	131	400	70	80	231,5	6	250
160	-	28	85	28	85	200	140	140	144	310	80	90	118,5	6	140
160	-	28	85	28	85	200	140	140	144	350	80	90	158,5	6	180
160	-	28	85	28	85	200	140	140	144	370	80	90	178,5	6	200
160	-	38	85	28	85	200	140	140	144	420	80	90	228,5	6	250
200	-	38	90	38	90	225	150	150	169	370	90	100	158,5	6	180
200	-	38	90	38	90	225	150	150	169	390	90	100	178,5	6	200
200	-	38	90	38	90	225	150	150	169	440	90	100	228,5	6	250
200	-	38	90	38	90	225	150	150	169	470	90	100	258,5	6	280
250	44	48	100	48	100	250	165	165	185	390	100	110	152,5	8	180
250	44	48	100	48	100	250	165	165	185	410	100	110	172,5	8	200
250	44	48	100	48	100	250	165	165	185	460	100	110	222,5	8	250

For special demands of torque transmission we are able to propose further solutions.

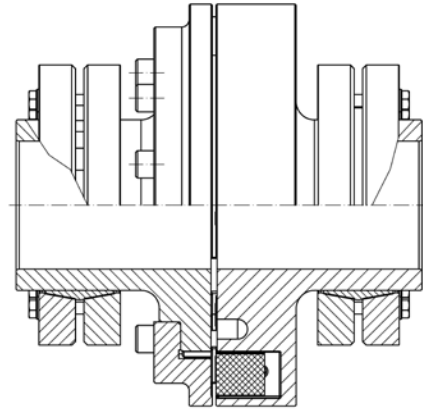

ELKU-N: flexible claw coupling with taper-lock-clamping unit

Table 13		characteristic values										
size	speed n [rpm]	torque [Nm]			torsion angle φ [°] at T_{KN}	dyn. torsional stiffness C_{dyn} [kNm/rad]		rel. damping Ψ [-]	moment of inertia J [kgm ²]		mass m [kg]	
		T_{Kmax}	$\pm T_{KW}$			T_{KN}	$0,5 \cdot T_{KN}$		buffer part	claw ring + spacer + hub	buffer part	claw ring + spacer + hub
6,3	5 000	63	126	16	4,5	5,4	2,5	0,9	0,0004	0,0013	0,6	1,9
6,3	5 000	63	126	16	4,5	5,4	2,5	0,9	0,0004	0,0014	0,6	2
10	5 000	100	200	25	4,5	8,3	3,8	0,9	0,0009	0,0028	0,9	2,7
10	5 000	100	200	25	4,5	8,3	3,8	0,9	0,0009	0,0031	0,9	3
16	5 000	160	320	40	4,5	12,6	5,8	0,9	0,002	0,0056	1,5	3,9
16	5 000	160	320	40	4,5	12,6	5,8	0,9	0,002	0,0060	1,5	4,3
16	5 000	160	320	40	4,5	12,6	5,8	0,9	0,002	0,0064	1,5	4,7
25	5 000	250	500	62	4,5	19,0	8,8	0,9	0,004	0,0099	2,5	5,3
25	5 000	250	500	62	4,5	19,0	8,8	0,9	0,004	0,0100	2,5	5,8
25	5 000	250	500	62	4,5	19,0	8,8	0,9	0,004	0,0110	2,5	6,3
25	5 000	250	500	62	4,5	19,0	8,8	0,9	0,004	0,0115	2,5	6,6
25	5 000	250	500	62	4,5	19,0	8,8	0,9	0,004	0,0120	2,5	7,1
40	4 900	400	800	100	4,5	26,0	11,9	0,9	0,007	0,0180	3,3	8
40	4 900	400	800	100	4,5	26,0	11,9	0,9	0,007	0,0190	3,3	8,5
40	4 900	400	800	100	4,5	26,0	11,9	0,9	0,007	0,0200	3,3	9
40	4 900	400	800	100	4,5	26,0	11,9	0,9	0,007	0,0210	3,3	9,3
40	4 900	400	800	100	4,5	26,0	11,9	0,9	0,007	0,0220	3,3	9,9
63	4 250	630	1 260	160	4,5	58,9	27,1	0,9	0,013	0,0300	4,7	9,8
63	4 250	630	1 260	160	4,5	58,9	27,1	0,9	0,013	0,0320	4,7	10,5
63	4 250	630	1 260	160	4,5	58,9	27,1	0,9	0,013	0,0340	4,7	11,3
63	4 250	630	1 260	160	4,5	58,9	27,1	0,9	0,013	0,0350	4,7	11,7
63	4 250	630	1 260	160	4,5	58,9	27,1	0,9	0,013	0,0370	4,7	12,7
100	3 800	1 000	2 000	250	4,5	88,5	40,6	0,9	0,023	0,0540	6,9	14,1
100	3 800	1 000	2 000	250	4,5	88,5	40,6	0,9	0,023	0,0580	6,9	15
100	3 800	1 000	2 000	250	4,5	88,5	40,6	0,9	0,023	0,0600	6,9	15,5
100	3 800	1 000	2 000	250	4,5	88,5	40,6	0,9	0,023	0,0650	6,9	16,5
160	3 400	1 600	3 200	400	4,5	138,8	63,8	0,9	0,04	0,0950	9,5	19,7
160	3 400	1 600	3 200	400	4,5	138,8	63,8	0,9	0,04	0,1000	9,5	20,8
160	3 400	1 600	3 200	400	4,5	138,8	63,8	0,9	0,04	0,1050	9,5	21,4
160	3 400	1 600	3 200	400	4,5	138,8	63,8	0,9	0,04	0,1100	9,5	22,6
200	3 000	2 000	4 000	500	4,5	236,0	108,4	0,9	0,07	0,1600	13	26
200	3 000	2 000	4 000	500	4,5	236,0	108,4	0,9	0,07	0,1700	13	26,7
200	3 000	2 000	4 000	500	4,5	236,0	108,4	0,9	0,07	0,1800	13	28,5
200	3 000	2 000	4 000	500	4,5	236,0	108,4	0,9	0,07	0,1900	13	29,5
250	2 750	2 500	5 000	625	4,5	305,4	140,3	0,9	0,12	0,2700	17,5	36
250	2 750	2 500	5 000	625	4,5	305,4	140,3	0,9	0,12	0,2800	17,5	37,2
250	2 750	2 500	5 000	625	4,5	305,4	140,3	0,9	0,12	0,3000	17,5	39

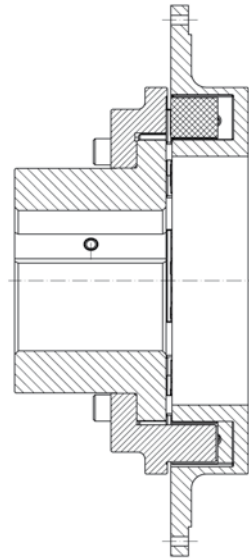

ELKU-N: flexible claw coupling in flange design

The hub length is not specified in the order, we will deliver according to catalogue.

Special designs are available on request:

- available in cast iron EN-GJS-400-15U DIN EN 1563,
- two keyways
- with locking thread
- finish bore without keyway (for clamping sets)
- versions with hole for removing the shaft
- hard chromed brake disk

type of the hub bore		bore tolerance H7 with keyway according to DIN 6885 version A, tolerance JS9			
hub bore	pilot bored	without keyway	one keyway	two keyways 120° turned	two keyways 180° turned
abbreviation	v	-	P1	P2	P3

Table 14



roll screen with ELKU-N



log washer drive with ELKU-N

materials

hub, claw ring, claw body and buffer part:
EN-GJL-250 DIN EN 1561

brake disk: EN 10025-2-S355J2+N / GS 30 DIN 1681

buffer: Perbunan 80 Shore A

spacer: EN-GJS-400-15U DIN EN 1563

alternative materials can be selected manufacturer

installation and operating conditions

The arrangement of the coupling parts to be connected to the shaft ends is desired.

The given permitted misalignment values provide general values under the following conditions is:

- load up to the rated torque
- operating speed $n = 1\,500$ rpm
(for $n < 1\,500$ rpm the maximum speed is valid)
- ambient temperature of $+ 30$ °C.
- maximum values in radial or angular misalignment

If both shifts at the same time, the values may only be used proportionately. In this case, please consult with the manufacturer.

balancing condition

In general, the elastic claw couplings in unbalanced state delivered.

In case of customer demands we are also able to deliver the couplings dynamical balance with quality Q6,3 (ISO recommendation 1940) or static balanced.

size selection in accordance with DIN 740 Part 2



Antriebstechnik

Getriebetechnik

Messtechnik

Spanntechnik

RINGSPANN AG

Sumpfstasse 7
CH-6303 Zug

Telefon +41 41 748 09 00
Telefax +41 41 748 09 09

www.ringspann.ch
info@ringspann.ch



Certified Welding
Company / GSI SLV

www.kupplungswerk-dresden.de