

Brake Caliper DT 250 FEM ... NC

spring activated – electrohydraulically released
Drum Brake according to DIN 15 435



Features	Code
Brake Caliper	D
Drum Brake	T
Frame size 250	250
Spring activated	F
Electrohydraulically released	E
Manual adjustment to accommodate friction block wear	M
Thrusters 451, 452 or 453 are available	451 452 453
Material: cast	NC

Example for ordering

Brake Caliper DT 250 FEM, thruster 452, material: cast

DT 250 FEM - 452 - NC

Technical Data

	Brake Caliper DT 250 FEM ... NC		
	with thruster 451	with thruster 452	with thruster 453
Brake drum diameter	Braking torque	Braking torque	Braking torque
mm	Nm	Nm	Nm
250	260	350	700
Clamping force	2600 N	3500 N	7000 N
Braking torque adjustable (optional)	20 - 100%	20 - 100%	20 - 100%
Nominal power	130 W	180 W	240 W
Oil volume	1,4 l	2,5 l	3,5 l
Voltage	230/400 V	230/400 V	230/400 V
Weight	39 kg	44 kg	46 kg

The braking torques shown in the table are based on a theoretical friction coefficient of 0,4.

Brake Caliper DT 250 FEM ... NC

spring activated – electrohydraulically released
Drum Brake according to DIN 15 435

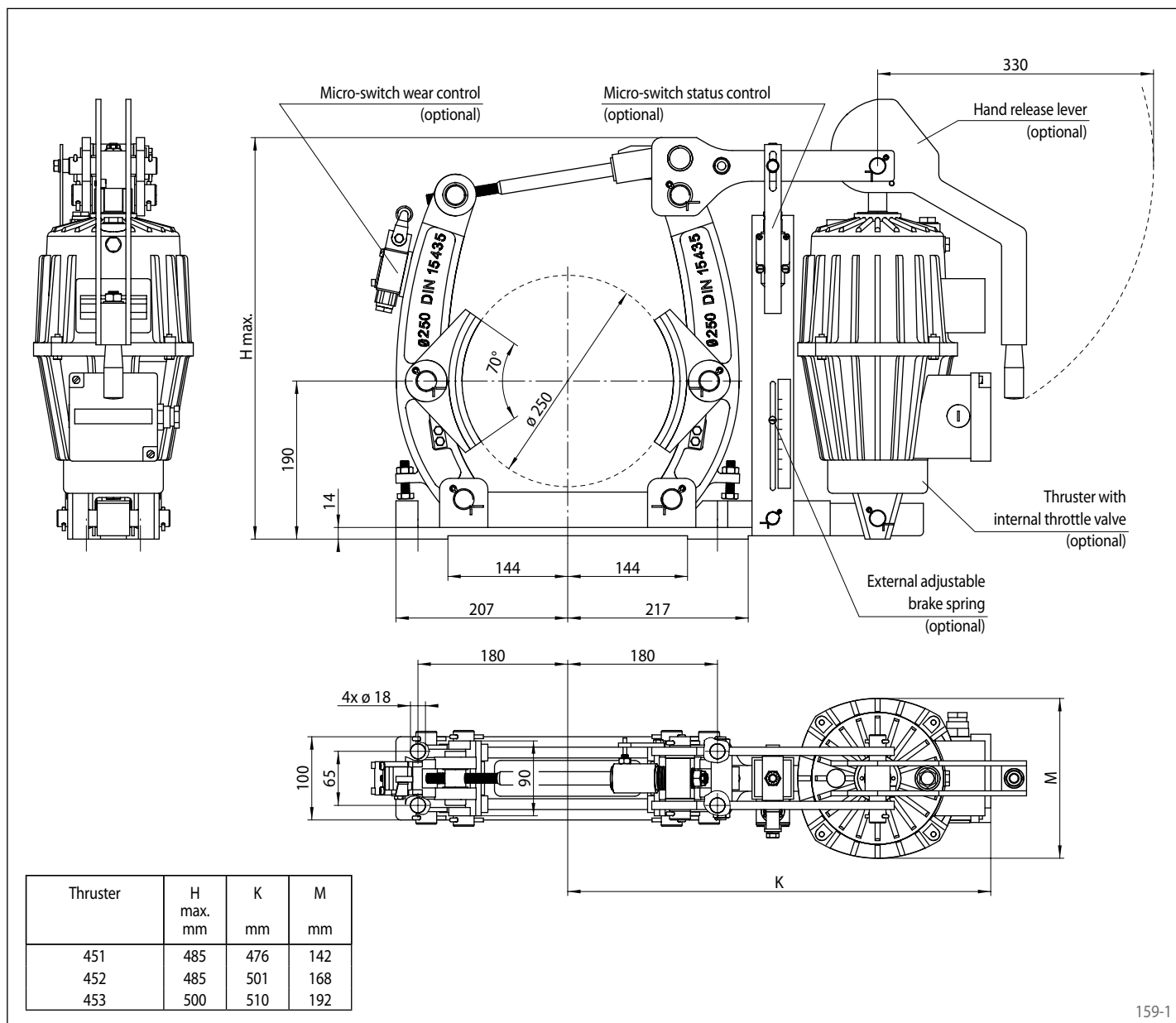

159-1

Options

- External adjustable brake spring
- Micro-switch wear control
- Micro-switch status control
- Hand release lever
- Thruster with internal throttle valve
- Thruster in heat resistant design
- Corrosion protected design
- Wider brake shoes and brake drums