

www. **RINGSPANN**[®].ch

INNESTI ELETTROMAGNETICI A DENTINI
ELECTROMAGNETIC TOOTH-TYPE COUPLINGS

07

spring activated - electromagnetically released



INNESTI A DENTINI A PRESSIONE DI MOLLE

In condizioni di lavoro, questa famiglia di innesti è mantenuta chiusa da una serie di molle elicoidali; alimentando la bobina, l'armatura viene attratta verso la coppa magnete, disinnestando la dentatura.

Diversamente dagli innesti normalmente aperti, la dentatura standard per questa famiglia è quella di tipo ②, triangolare senza gioco, che consente unicamente innesti da fermo o a velocità sincrona.

Sono disponibili le dentature trapezoidale ①, a dente di sega ③ e ④ o speciale con fase ⑤.

TOOTH-TYPE SPRING LOADED COUPLINGS

In working conditions, this family of couplings is held permanently engaged by the actions of a series of coil springs; when current is supplied to the coil, the magnetic field generated attracts the armature towards the magnet body, disengaging the tothing.

Unlike the normally opened type, standard teeth for this family are type ②, triangular without play, which allow engaging at stand still or with synchronous speed only.

Trapezoidal ①, saw-toothed ③ and ④, along with special with phase ⑤ are also available

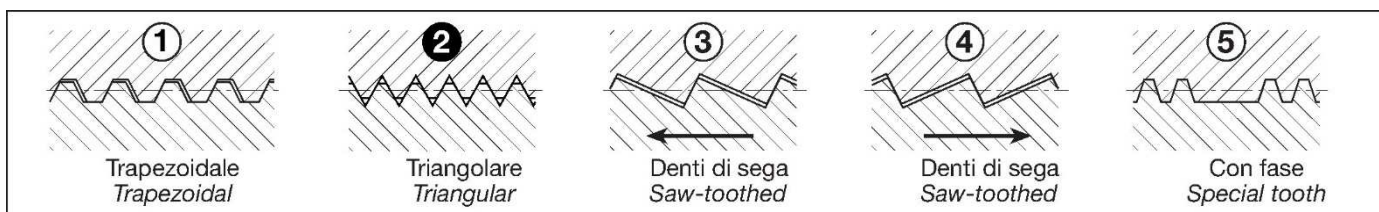

EC-N/Z

ESB-N/Z

EC-N/Z-F

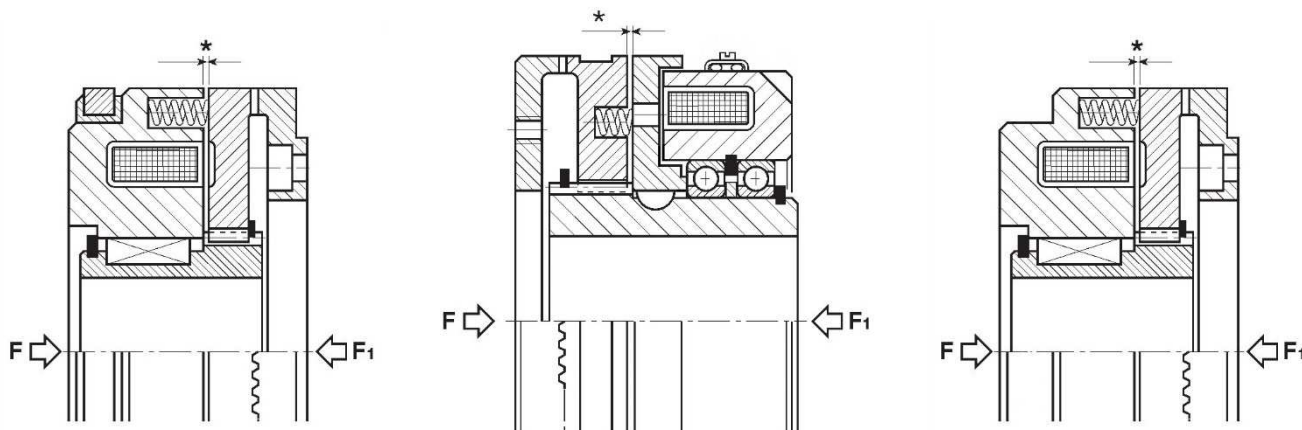

REGOLAZIONE DEL TRAFERRO

- Montare l'innesto a dentini
- Innestare la dentatura
- Applicare una forza in direzione F o F₁

Controllare il traferro * in tre punti (120°) con uno spessimetro: il valore deve essere quello indicato nelle relative tabelle

AIR GAP ADJUSTMENT

- Mount the tooth-type coupling
- The tothing has to be engaged
- Apply force in the direction F or F₁

Check the size of the air gap * at 3 points (120°) with a thickness gauge; it should be as indicated in the relevant tables

TENSIONE DI MANTENIMENTO

Per tutti gli innesti a dentini a pressione di molle, soprattutto per quelli di grosse dimensioni, in caso di disinnesto prolungato nel tempo si raccomanda di dimezzare la tensione nominale una volta eseguito il disinnesto.

POSITION HOLDING VOLTAGE

For all our spring-applied tooth-type couplings and in particular the bigger sizes, if you plan to let the coupling uncoupled for a long period we highly recommend to halve the nominal voltage after the disengagement

EC-N/Z

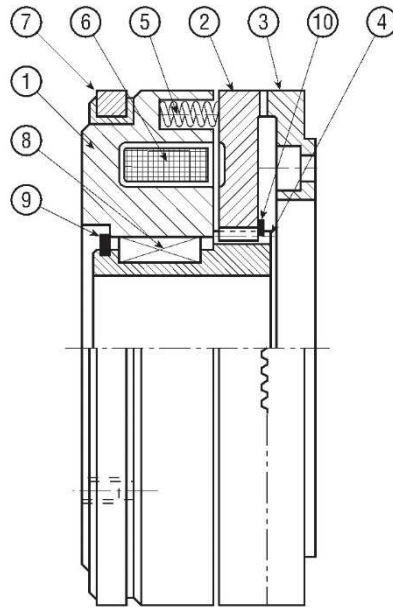

DISTINTA PARTICOLARI

- 1. COPPA MAGNETE
- 2. ARMATURA DENTATA
- 3. CAMPANA DENTATA
- 4. MOZZO DENTATO
- 5. MOLLA
- 6. BOBINA
- 7. ANELLO COLLETTORE
- 8. CHIAVETTA
- 9. ANELLO DI SICUREZZA ESTERNO
- 10. ANELLO DI SICUREZZA ESTERNO

PARTS LIST

- 1. *MAGNET CUP*
- 2. *TOOTHED ARMATURE*
- 3. *TOOTHED COVER*
- 4. *TOOTHED HUB*
- 5. *SPRING*
- 6. *COIL*
- 7. *COLLECTOR RING*
- 8. *KEY*
- 9. *OUTER SAFETY RING*
- 10. *OUTER SAFETY RING*

ESEMPI DI MONTAGGIO

EXAMPLES OF MOUNTING

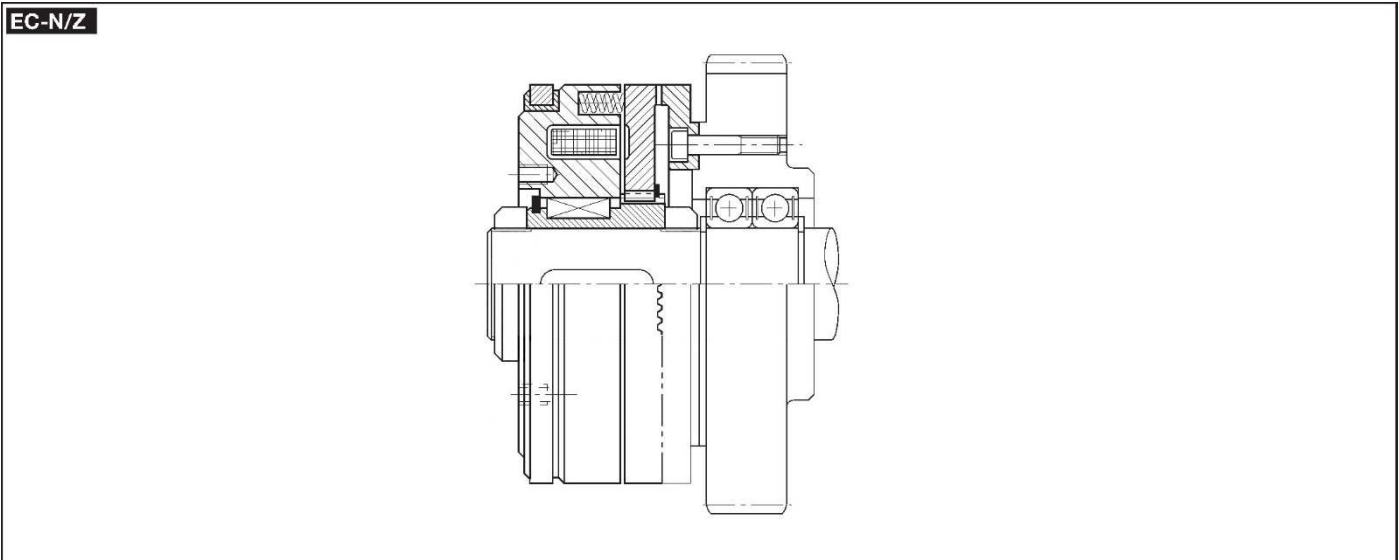

SERIE/MODEL
CODICE/CODE

EC-N □□□/Z
07.50.□□□.01

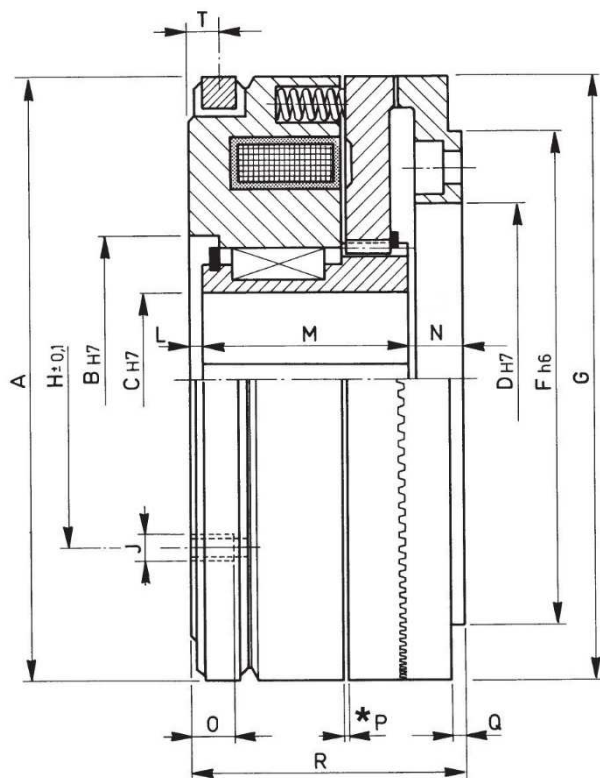
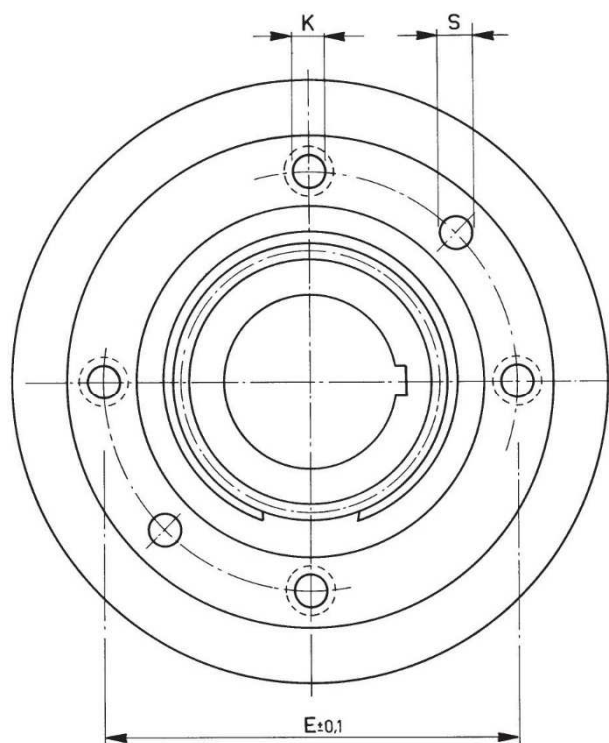

* P = Regolazione traferro / Air gap adjustment (pag. 51)

□□□	Momento Torque Ms max. (Nm)	Giri/1' R.P.M. limit max	Watt		Spinta assiale sulla corona dentata Axial thrust on the crown ring daN			Peso Weight kg
			20°	120°				
082	25	4500	30	22			22	1,8
090	35	4000	38	27			30	2
105	70	4000	45	32			51	2,7
115	100	3500	50	36			67	3,5
125	160	3300	65	47			100	4,4
140	250	3000	85	61			140	6,3
160	400	2500	96	69			190	9
185	650	2200	115	83			270	14
215	1050	2000	135	97			370	20

□□□	A	B	C Max.	D	E	F	G	H	J N°xφ	K N°xφ	L	M	N	O Max.	P	Q	R	S N°xφ	T
082	82	40	18	46	56	65	82	54	4xM5	4x4,5	2	40	5	8	0,8	1,5	47	2x4	5
090	90	46	25	53	64	75	90	54	4xM4	4x5,5	2	31,5	6,5	10	0,8	2	40	2x5	5
105	105	52	28	65	75	85	105	62	4xM5	4x5,5	2	36	6	10	0,7	2	44	2x5	5
115	115	58	32	70	85	100	115	68	4xM6	4x6,5	2,5	38,5	9	12	1	2	50	2x6	6
125	125	62	35	75	90	105	125	72	4xM6	4x6,5	2,5	44,5	11	12	1,1	2,5	58	2x8	6
140	140	70	42	85	100	115	140	80	4xM6	4x6,5	2,5	54,5	10	13	1,1	2,5	67	3x8	7
160	166	78	45	95	115	130	160	90	4xM8	6x8,5	3	59	13	15	1,1	3	75	3x8	8
185	185	84	50	115	135	155	185	106	6xM8	6x8,5	3	68	14	15	1	3	85	3x10	8
215	210	96	60	130	155	180	215	124	6xM8	6x8,5	3	81	16	15	1,5	4	100	3x10	8

ESB-N/Z

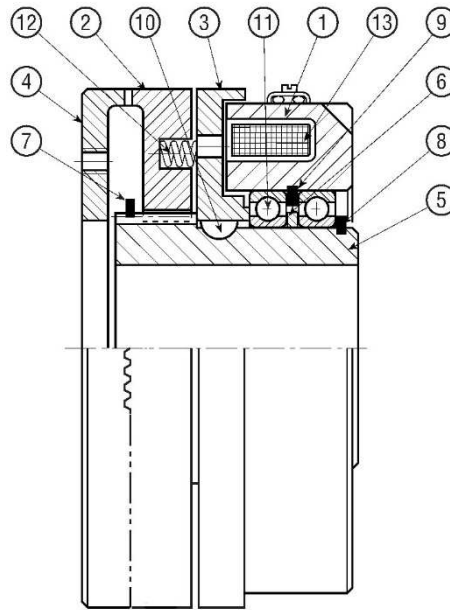

DISTINTA PARTICOLARI

1. COPPA MAGNETE
2. ARMATURA DENTATA
3. ROTORE
4. CAMPANA DENTATA
5. MOZZO
6. ANELLI DISTANZIALI
7. ANELLO DI SICUREZZA ESTERNO
8. ANELLO DI SICUREZZA ESTERNO
9. ANELLO DI SICUREZZA INTERNO
10. CHIAVETTA DI FERMO
11. CUSCINETTI
12. MOLLA
13. BOBINA

PARTS LIST

1. *MAGNET CUP*
2. *TOOTHED ARMATURE*
3. *ROTOR*
4. *TOOTHED CUP HOUSING*
5. *HUB*
6. *SPACER RINGS*
7. *OUTER SAFETY RING*
8. *OUTER SAFETY RING*
9. *INNER SAFETY RING*
10. *LOCK KEY*
11. *BEARINGS*
12. *SPRING*
13. *COIL*

ESEMPI DI MONTAGGIO

EXAMPLES OF MOUNTING

ESB-N/Z

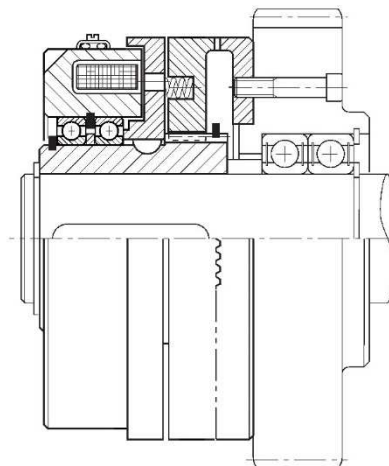

SERIE/MODEL
CODICE/CODE

ESB-N □□□/Z
07.80.□□□.01

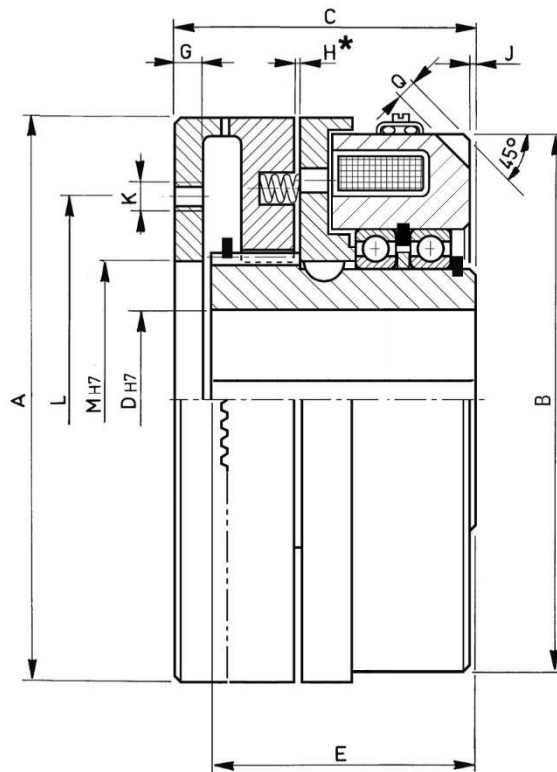
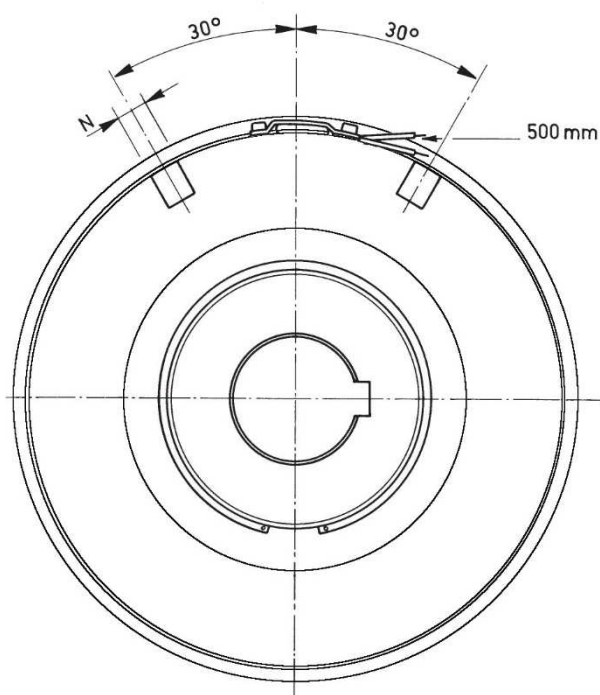

* H = Regolazione traferro / Air gap adjustment (pag. 51)

□□□	Momento Torque Ms max. (Nm)	Giri/1' R.P.M. limit Max.	Watt		Spinta assiale sulla corona dentata Axial thrust on the crown ring daN	Peso Weight kg
			20°	120°		
090	50	4000	50	36	30	2,5
105	100	3600	78	56	45	3,5
115	200	3300	84	60	65	4,2
140	400	2700	135	97	115	7,5
185	800	2100	150	108	180	17,1
215	1600	1800	175	126	330	33,8
265	3200	1450	320	230	900	50,9
320	6400	1200	720	518	1500	98,4
385	12800	1000	1100	792	2000	184,4

□□□	A	B	C	D		E	G	H	J	K N°xφ	L	M		N	Q
				Min.	Max.							Min.	Max.		
090	100	96	58	16	30	51	5	0,8	1	4xM6	68	40	58	10	4
105	114	108,6	63	20	38	55	6	0,8	1	4xM6	82	40	70	10	4
115	125	120	65	20	42	57	6	0,9	1	6xM6	92	50	80	10	4
140	154	146	80	25	55	71	7	1	1	6xM8	110	65	95	10	6
185	205	194	100	30	75	90	8	1,1	1,2	6xM10	148	100	130	10	6
215	245	231	145	40	80	130	12	1,3	14,5	6xM12	175	110	153	12	7
265	290	274	165	55	95	160	15	1,6	19,5	12xM12	240		215	16	10
320	350	329	200	75	110	196	20	1,7	22	12xM14	290		260	18	12
385	425	405	245	90	135	240	25	2,3	25	12xM16	355		315	20	12

ESBR-N/Z

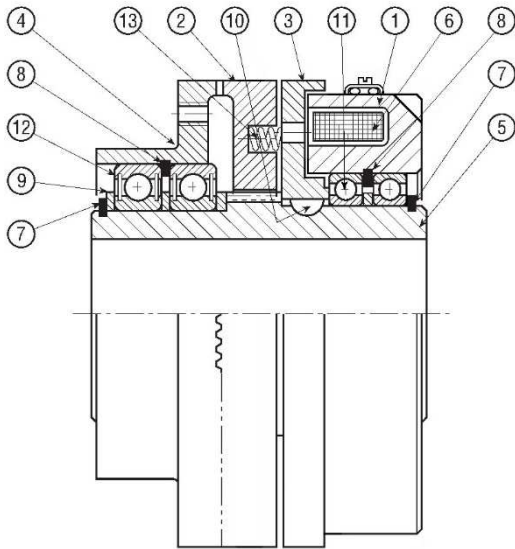

ESBG-N/Z

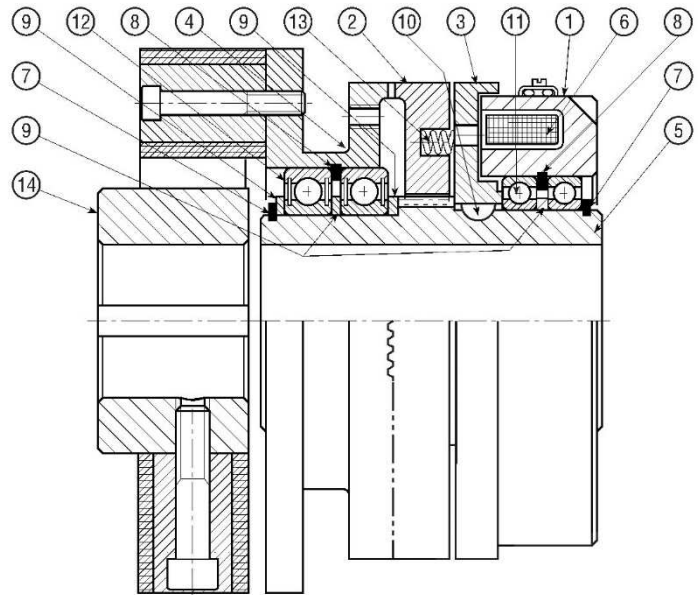

DISTINTA PARTICOLARI

1. COPPA MAGNETE
2. ARMATURA DENTATA
3. ROTORE
4. RINVIO
5. MOZZO
6. BOBINA
7. ANELLO DI SICUREZZA ESTERNO
8. ANELLO DI SICUREZZA INTERNO
9. ANELLO DISTANZIATORE
10. CHAVETTA DI FERMO
11. CUSCINETTI INNESTO
12. CUSCINETTI RINVIO
13. MOLLA
14. GIUNTO ELASTICO

PARTS LIST

1. *MAGNET CUP*
2. *TOOTHED ARMATURE*
3. *ROTOR*
4. *TRANSMISSION SLEEVE*
5. *HUB*
6. *COIL*
7. *OUTER SAFETY RING*
8. *INNER SAFETY RING*
9. *SPACER RING*
10. *LOCK KEY*
11. *COUPLING BEARINGS*
12. *TRANSMISSION SLEEVE BEARINGS*
13. *SPRING*
14. *FLEXIBLE COUPLING*

ESEMPI DI MONTAGGIO

EXAMPLES OF MOUNTING

ESBR-N/Z

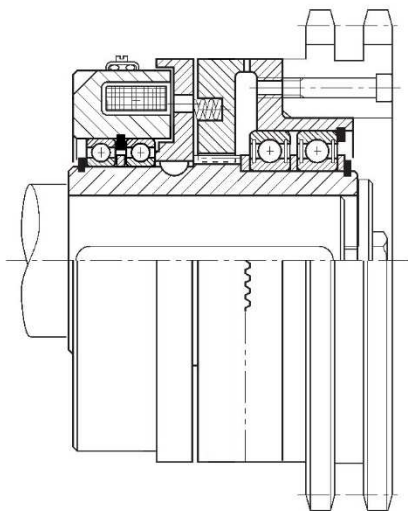

ESBG-N/Z

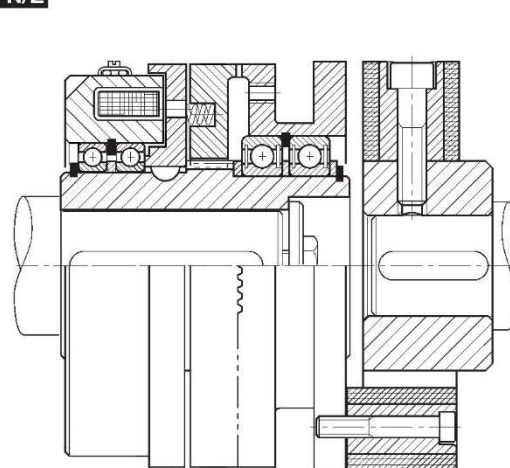

SERIE/MODEL	ESBR-N □□□/Z
CODICE/CODE	07.84.□□□.01

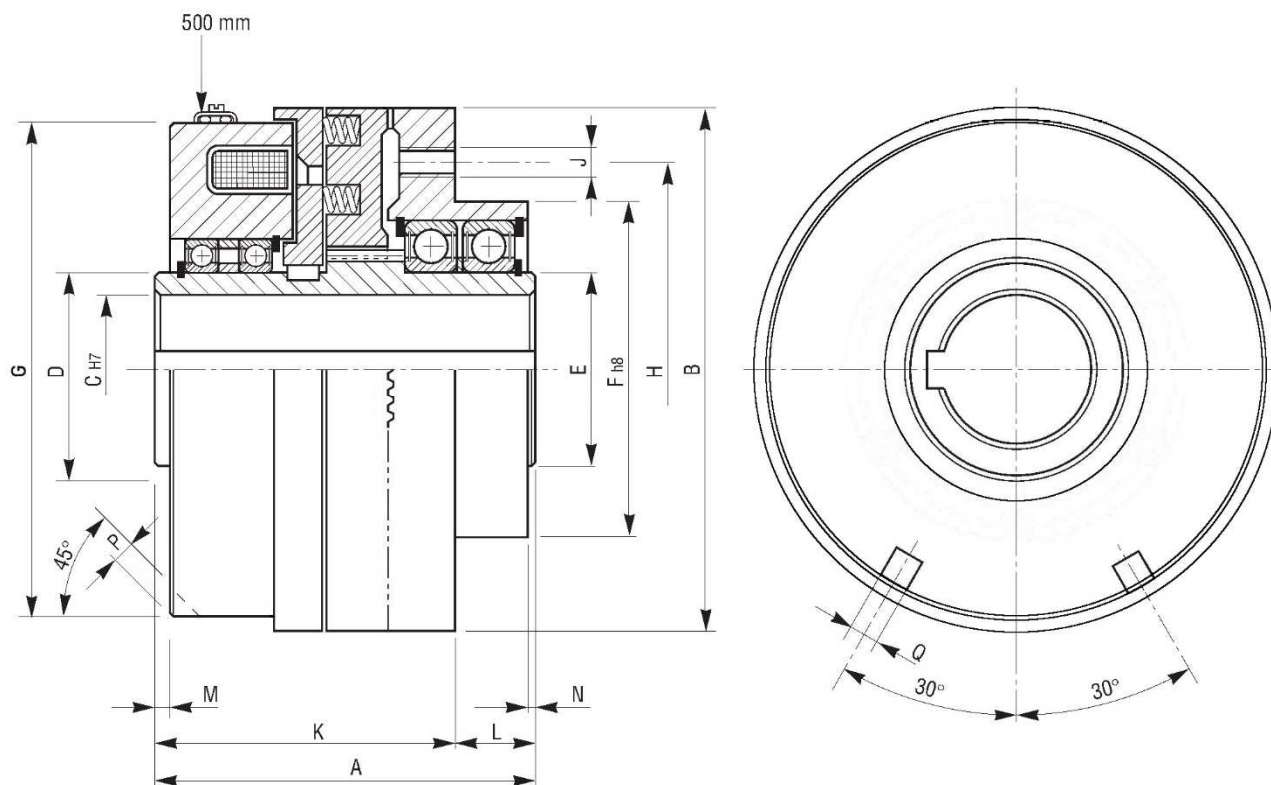

□□□	Momento Torque Ms max. (Nm)	Giri/1' R.P.M. limit Max.	Watt		Peso Weight kg
			20°	120°	
090	50	4000	50	36	2,9
105	100	3600	78	56	4,6
115	200	3300	84	60	5,6
140	400	2700	135	97	10,1
185	800	2100	150	108	23,2
215	1600	1800	175	126	40,4
265	3200	1450	320	230	65
320	6400	1200	720	518	121,7
385	12800	1000	1100	792	240

□□□	A	B	C		D	E	F	G	H	J N°xφ	K	L	M	N	PxQ
			Min.	Max.											
090	86	100	15	30	40	40	75	96	86	3xM6	61	25	1	1	4x10
105	94	114	15	35	50	45	84	108,6	96	3xM6	69	25	1,5	1	4x10
115	98	125	20	38	55	50	90	120	105	3xM8	70	28	1	1	4x10
140	116	154	25	50	70	65	115	146	135	6xM8	83	33	1	1	6x10
185	152	205	30	70	100	90	154	194	175	6xM10	109,5	42,5	1,2	1,5	6x10
215	190	245	40	80	110	105	180	231	205	6xM12	141	49	10,5	0	7x12
265	230	290	45	95	120	120	200	274	240	12xM12	165	65	19,5	1	10x16
320	290	350	60	110	150	150	245	329	290	12xM14	213	77	22	14	12x18
385	340	425	90	130	190	190	320	405	355	12xM16	283	57	27	2	12x20

SERIE/MODEL	ESBG-N □□□/Z
CODICE/CODE	07.86.□□□.01

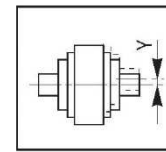
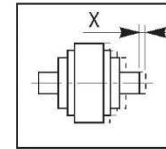
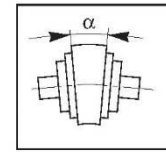
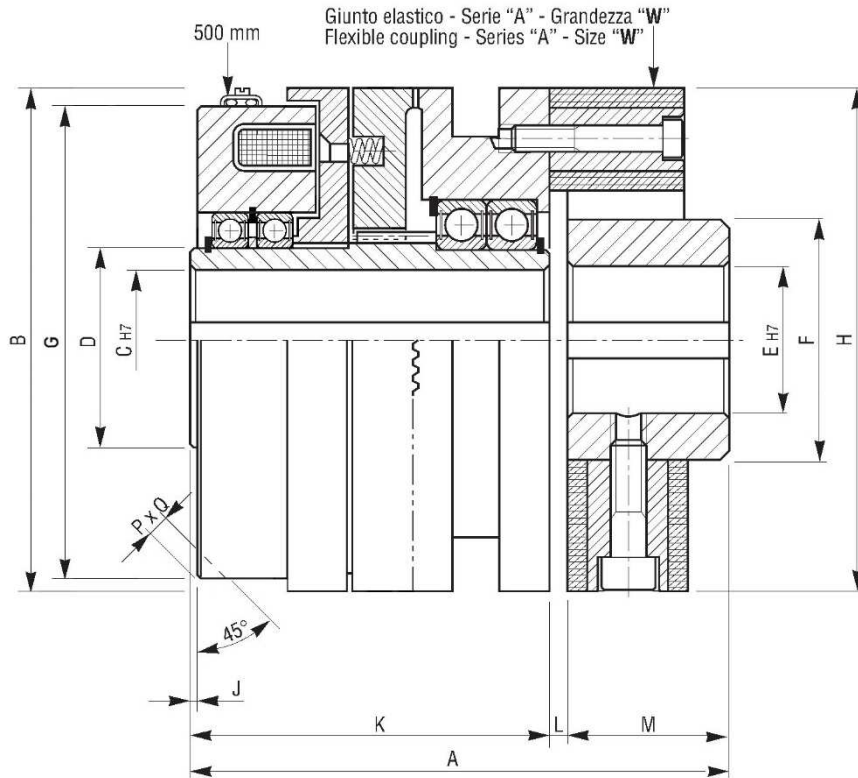

□□□	Momento Torque Ms max. (Nm)	Giri/1' R.P.M. limit Max.		Watt		Grandezza giunto Coupling size W	Peso Weight kg
		20°	120°	20°	120°		
090	50	4000	36	50	36	4	3,5
105	100	3600	56	78	56	8	5,8
115	200	3300	60	84	60	12	6,9
140	400	2700	97	135	97	25	12,7
185	800	2100	108	150	108	30	28,5
215	1600	1800	126	175	126	90	50,8
265	3200	1450	230	320	230	140	77,8
320	6400	1200	518	720	518	250	142,2
385	12800	1000	792	1100	792	600	286,3

□□□	A	B	C		D	E		F	G	H	J	K	L	M	PxQ	X	Y	α
			Min.	Max.		Max.	Max.											
090	120	100	15	30	40	30	45	96	100	1	86	4	30	4x10	2	1	1°	
105	140	114	15	35	50	38	60	108,6	120	1,5	94	4	42	4x10	2	1	1°	
115	144	125	20	38	55	38	60	120	122	1	98	4	42	4x10	3	1	1°	
140	177	154	25	50	70	55	85	146	170	1	116	6	55	6x10	3	1	1°	
185	226	205	30	70	100	65	100	194	200	1,2	152	8	66	6x10	3	1	1°	
215	278	245	40	80	110	85	125	231	260	10,5	190	8	80	7x12	3	1	1°	
265	318	290	45	95	120	85	125	274	260	19,5	230	8	80	10x16	3	1	1°	
320	398	350	60	110	150	115	160	329	340	22	290	8	100	12x18	3	1	1°	
385	510	425	90	130	190	140	200	405	470	27	340	15	155	12x20	3	1	1°	

EC-N/Z-F

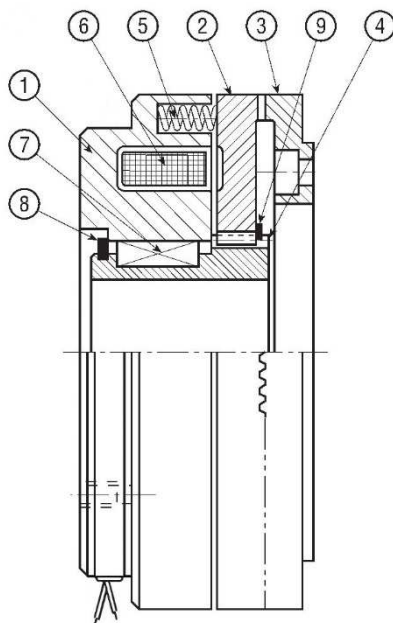

DISTINTA PARTICOLARI

1. COPPA MAGNETE
2. ARMATURA DENTATA
3. CAMPANA DENTATA
4. MOZZO DENTATO
5. MOLLA
6. BOBINA
7. CHIAVETTA
8. ANELLO DI SICUREZZA ESTERNO
9. ANELLO DI SICUREZZA ESTERNO

PARTS LIST

1. MAGNET CUP
2. TOOTHED ARMATURE
3. TOOTHED COVER
4. TOOTHED HUB
5. SPRING
6. COIL
7. KEY
8. OUTER SAFETY RING
9. OUTER SAFETY RING

ESEMPI DI MONTAGGIO

EXAMPLES OF MOUNTING

EC-N/Z-F

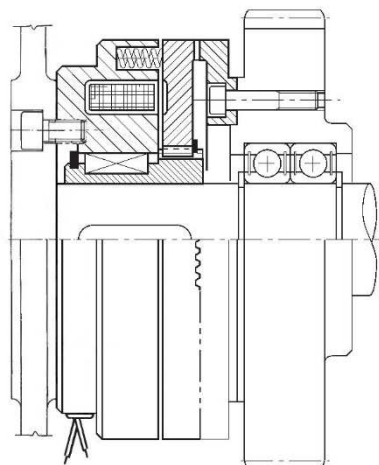

SERIE/MODEL
CODICE/CODE

EC-N □□□/Z-F
07.90.□□□.01

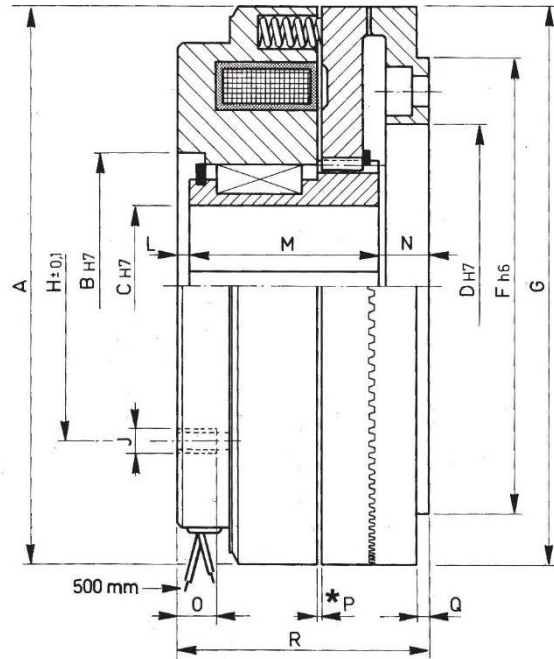
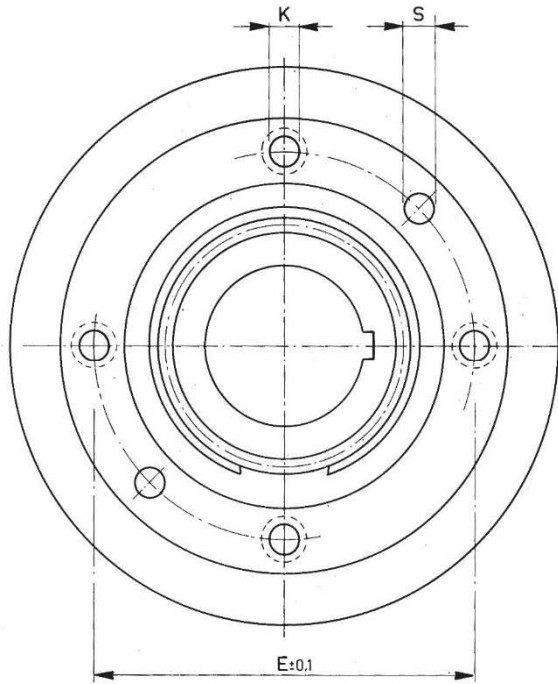

* P = Regolazione traferro / Air gap adjustment (pag. 51)

□□□	Momento Torque Ms max. (Nm)	Giri/1' R.P.M. limit Max.	Watt		Spinta assiale sulla corona dentata Axial thrust on the crown ring daN		Peso Weight kg
			20°	120°			
082	25	4500	30	22	22	1,8	
090	35	4000	38	27	30	2	
105	70	4000	45	32	51	2,7	
115	100	3500	50	36	67	3,5	
125	160	3300	65	47	100	4,4	
140	250	3000	85	61	140	6,3	
160	400	2500	96	69	190	9	
185	650	2200	115	83	270	14	
215	1050	2000	135	97	370	20	

□□□	A	B	C Max.	D	E	F	G	H	J N°xφ	K N°xφ	L	M	N	O Max.	P	Q	R	S N°xφ
082	82	40	18	46	56	65	82	54	4xM5	4x4,5	2	40	5	8	0,8	1,5	47	2x4
090	90	46	25	53	64	75	92	54	4xM4	4x5,5	2	31,5	6,5	10	0,8	2	40	2x5
105	105	52	28	65	75	85	105	62	4xM5	4x5,5	2	36	6	10	0,7	2	44	2x5
115	115	58	32	70	85	100	114	68	4xM6	4x6,5	2,5	38,5	9	12	1	2	50	2x6
125	125	62	35	75	90	105	125	72	4xM6	4x6,5	2,5	44,5	11	12	1,1	2,5	58	2x8
140	140	70	42	85	100	115	140	80	4xM6	4x6,5	2,5	54,5	10	13	1,1	2,5	67	3x8
160	160	78	45	95	115	130	165	90	4xM8	6x8,5	3	59	13	15	1,1	3	75	3x8
185	185	84	50	115	135	155	185	106	6xM8	6x8,5	3	68	14	15	1	3	85	3x10
215	215	96	60	130	155	180	215	124	6xM8	6x8,5	3	81	16	15	1,5	4	100	3x10

SERIE/MODEL
CODICE/CODE

①	FF □□□/Z
	45.05.□□□.01

②	FF □□□/ZB
	45.06.□□□.01

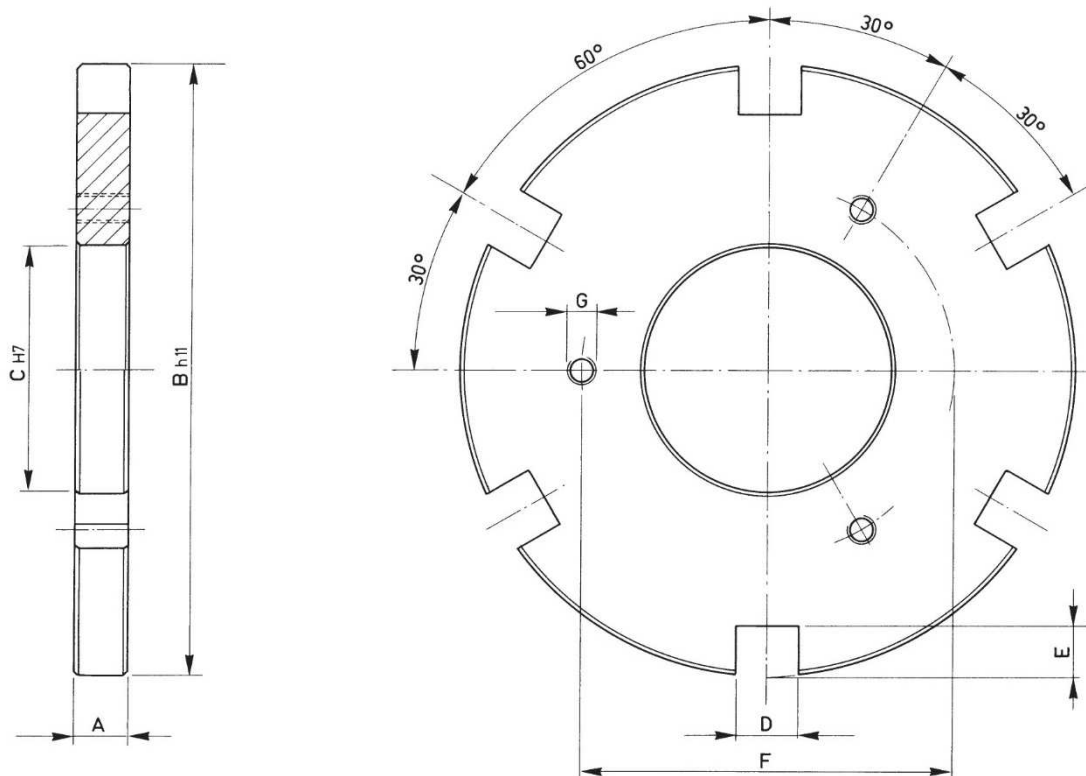

□□□ ①	A	B	C	D	E	F	G	Peso Weight kg	Per innesto a denti tipo: For toothed coupling type:		
									EC/Z – EC/Z-F	ECF/Z – EBLF/Z	ESB/Z
060	9	60	23	6	4	40	3xM3	0,16	060		060
070	9	70	25	7	5	45	3xM3	0,22	070		070
082	9	82	35	8	7,5	55	3xM4	0,28	082	082	
095	9	95	45	8	7,5	65	3xM4	0,36	095	095	
114	10	114	50	10	9	80	3xM4	0,60	114	114	
134	11	134	60	10	10	100	3xM5	0,92	134		
140	11	140	70	10	9	100	3xM5	0,95	140	140	
166	13	166	80	12	11	120	3xM6	1,6	166	166	
195	15	195	90	15	12	150	3xM6	2,6	195	195	195
210	16	210	100	18	12	150	3xM6	3,2	210	210	210
240	17	240	110	20	13	150	3xM6	4,6	240	240	240
260	19	258	130	20	15	170	6xM6	5,5	260	260	260

□□□ ②	A	B	C	D	E	F	G	Peso Weight kg	Per innesto a denti tipo: For toothed coupling type:		
									EC/Z – EC/Z-F	ECF/Z – EBLF/Z	ESB/Z
082	9	82	35	8	7,5	52	3xM4	0,28			082
095	9	95	45	8	8,5	62	3xM4	0,36			095
114	10	114	50	10	9	70	3xM4	0,63			114
134	11	134	60	10	10	85	3xM5	0,92			134
166	13	166	80	12	13,5	108	3xM6	1,6			166

SERIE/MODEL
CODICE/CODE

①	FD □□□/ZD
	45.07.□□□.01

②	FD □□□/ZDB
	45.08.□□□.01

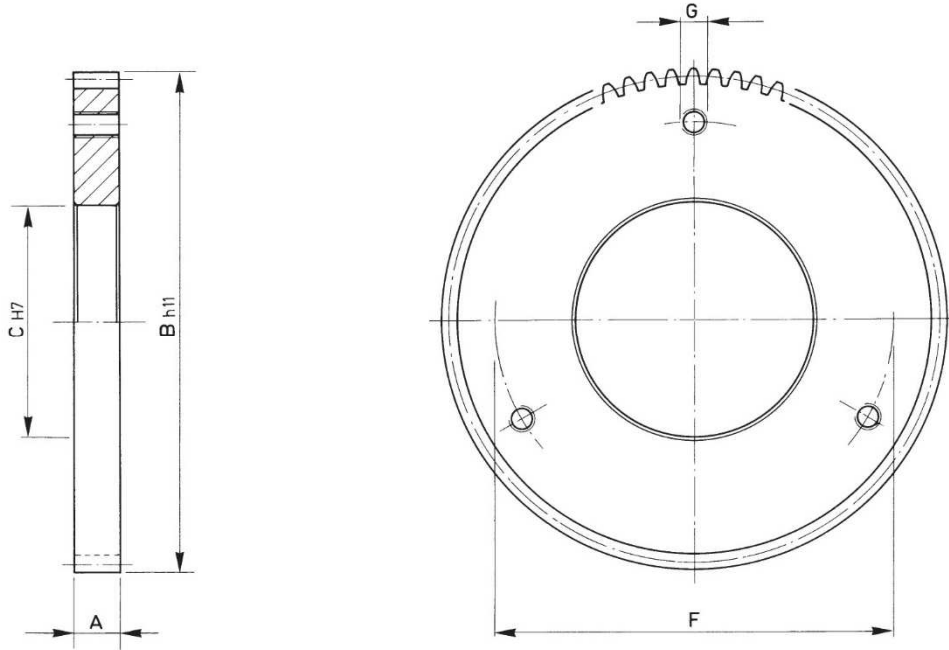

Dentatura DIN 5480

□□□	A	B	C	F	G	D _B	m	α	z	Peso Weight kg	Per innesto a denti tipo: For toothed coupling type:		
①											EC/ZD – EC/ZD-F	ECF/ZD – EBLF/ZD	ESB/ZD
060	9	54,6	23	40	3xM3	55	2	30°	26	0,12	060		060
070	9	64,6	25	45	3xM3	65	2	30°	31	0,18	070		070
082	9	74,6	35	55	3xM4	75	2	30°	36	0,22	082	082	
095	9	87,6	45	65	3xM4	88	2	30°	42	0,29	095	095	
114	10	104,6	50	80	3xM4	105	2	30°	51	0,50	114	114	
134	11	119,4	60	100	3xM5	120	3	30°	38	0,67	134		
140	11	119,4	70	100	3xM5	120	3	30°	38	0,59	140	140	
166	13	149,4	80	120	3xM6	150	3	30°	48	1,2	166	166	
195	15	179	90	150	3xM6	180	5	30°	34	2	195	195	
210	16	189	100	150	3xM6	190	5	30°	36	2,35	210	210	210
240	17	219	110	150	3xM6	220	5	30°	42	3,5	240	240	240
260	19	239	130	170	6xM6	240	5	30°	46	4,4	260	260	260
295	19	259	120	215	9xM8	260	5	30°	50	5,8	295		295
330	25	299	150	240	9xM8	300	5	30°	58	9,8			330
360	30	319	180	270	12xM8	320	5	30°	62	12,2			360

□□□	A	B	C	F	G	D _B	m	α	z	Peso Weight kg	Per innesto a denti tipo: For toothed coupling type:		
②											EC/ZD – EC/ZD-F	ECF/ZD – EBLF/ZD	ESB/ZD
082	9	64,6	35	52	3xM4	65	2	30°	31	0,15			082
095	9	74,6	45	62	3xM4	75	2	30°	36	0,18			095
114	10	87,6	50	70	3xM4	88	2	30°	42	0,30			114
134	11	104,6	60	85	3xM5	105	2	30°	51	0,47			134
166	13	129,4	80	108	3xM6	130	3	30°	42	0,76			166
195	15	169	90	150	3xM6	170	5	30°	32	1,7			195